

1 PRACTICAPARK



PRACTICAPARK

Two-floor semi-automatic parking system
above ground

DATA SHEET



WE
EXPAND
YOUR PARKING
CAPACITY

TABLE OF CONTENTS

GENERAL DESCRIPTION	2
LENGTH DETAILS	3
VEHICLE DETAILS, CLEARANCE & DIMENSIONS	4
HEIGHT DETAILS	5
WIDTH DIMENSIONS	6
ELECTRICITY INSTALLATION DIAGRAM	7
LOADS AND CONSTRUCTION DETAILS	8
SLIDING DOOR DETAILS	9
GROUND FLOOR PLATFORM GUIDE TRACK DETAILS	10
FUNCTION	10
TECHNICAL INFORMATION	11
SERVICES TO BE PROVIDED BY THE CUSTOMER	12
CERTIFICATES	12

GENERAL DESCRIPTION

- ▣ Practicapark is a new generation semi-automatic parking system for an indoor application. It almost doubles parking capacity in a parking space while using the same amount of conventional space.
- ▣ Practicapark is a modular system which allows us to add modules one to another without changing the basics of it.
- ▣ Each system has one transfer space so that no one needs to leave their car keys to a valet or an operator.
- ▣ The ground floor platforms move horizontally while the upper floor platforms move vertically.
- ▣ The height and width of the platform can be customized according to the customer's request. (see "Height and Width Details", page 5 and 6).
- ▣ Sanpark provides clear instructions at every operating point. The operating screen is installed in front of the columns or anywhere desired.
- ▣ Hot-dip galvanization is applied to the main construction. It is safe and secured with an automatic electromagnetic mechanic position lock.
- ▣ All dimensions in the datasheet are minimum and tolerance for dimensions is +3/-0 cm.

LENGTH DETAILS

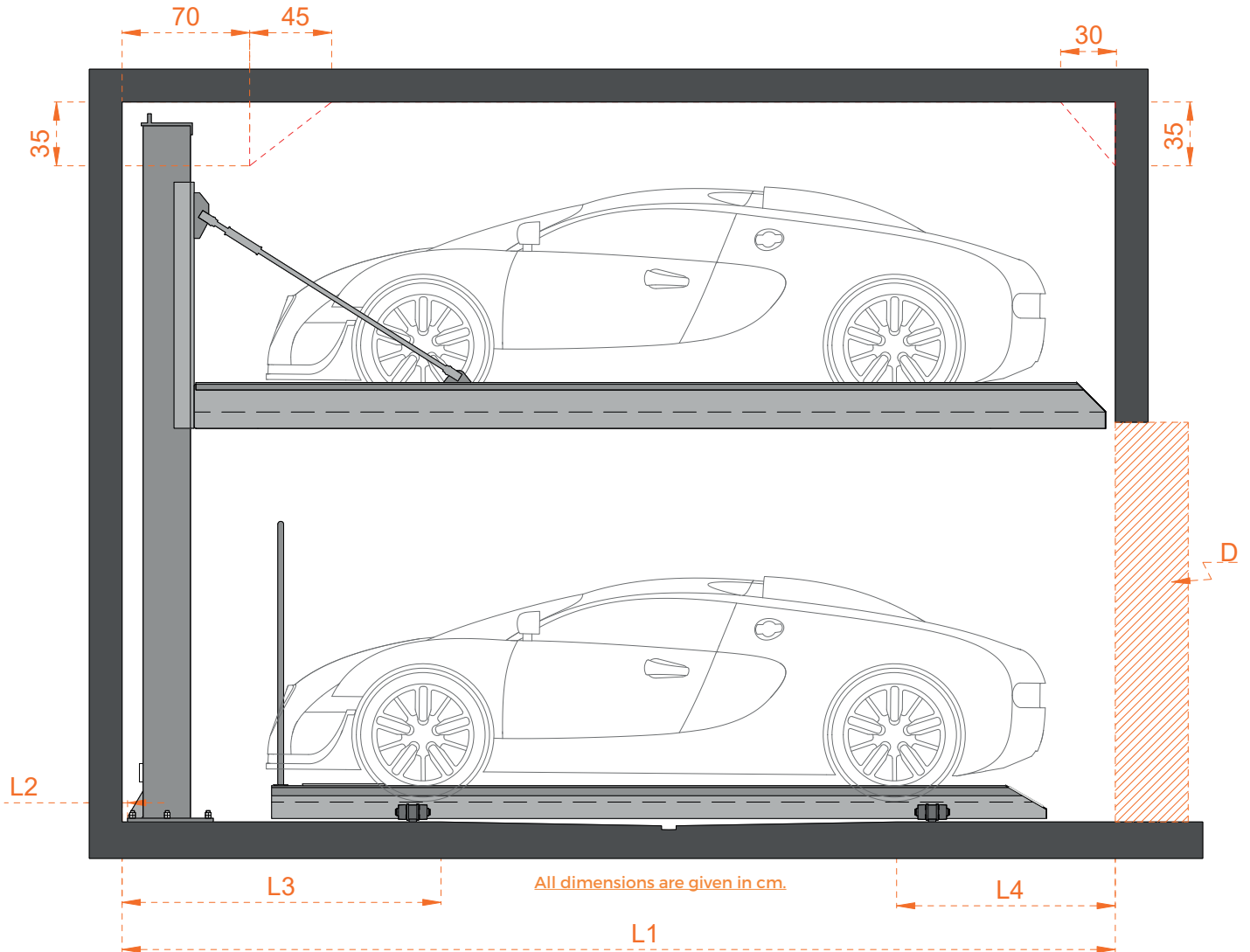

- Maximum vehicle length dimensions can be like the following table. In case of shorter and longer versions, please consult Sanpark.

PRACTICAPARK LENGTH DIMENSIONS

Maximum Vehicle Length	Required Space (L1)	Space (L2)	Gradient Free Space (L3)	Gradient Free Space (L4)
500 cm	545 cm	3 cm	145 cm	125 cm
510 cm	555 cm	3 cm	145 cm	135 cm
520 cm	565 cm	3 cm	145 cm	145 cm
530 cm	575 cm	3 cm	145 cm	155 cm

****Shorter versions are available upon request.**

- Doors (D) are required according to DIN EN 14010. Please see "Sliding Door Details", page x for more detail.
- Practicapark's columns shall be at least 3 cm (L2) away from the wall to provide enough clearance for installation.
- Gradient free space (L3 and L4) indicates a space where shall be no gradient or slope.
- It is our customer responsibility to plan drainage space on the space shown in the picture as (P).

Operation

With the help of "Electronic Operation System", users securely operate the system with their cards, remote controls, chips, or apps.

VEHICLE DETAILS, CLEARANCE & DIMENSIONS

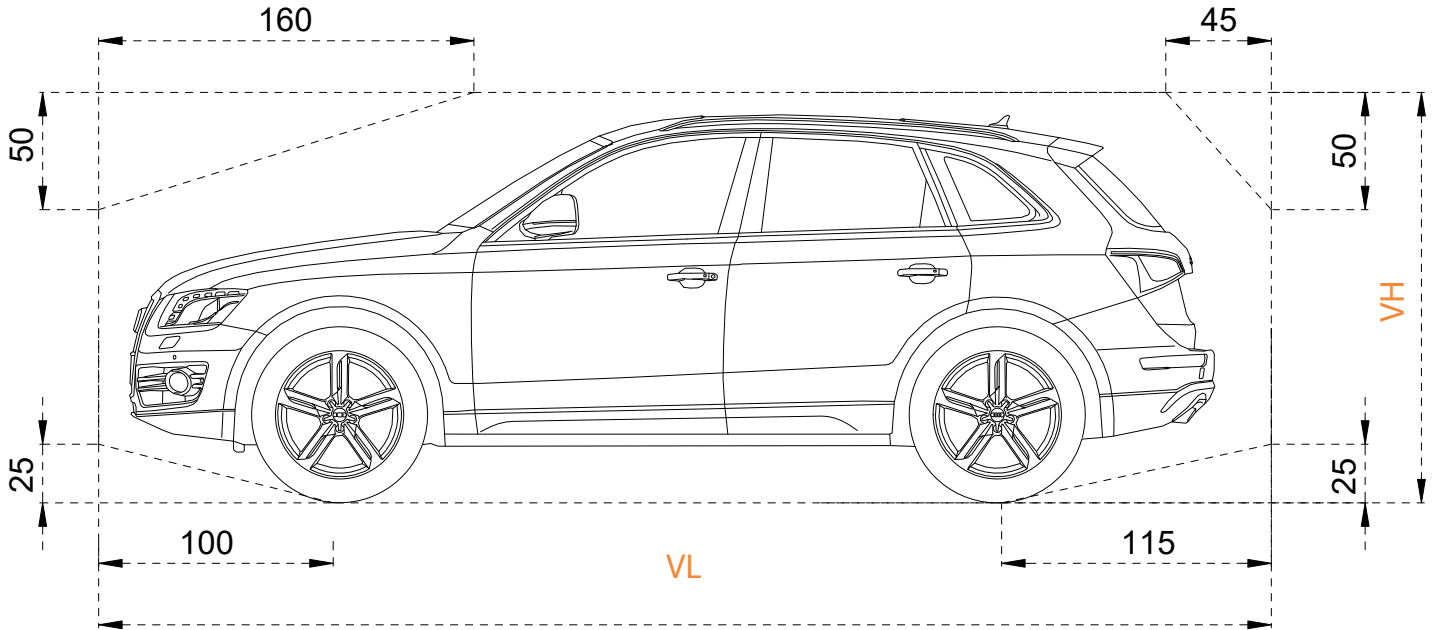

Vehicle Length (VL)	see "Length Details", page 3
Vehicle Height (VH)	see "Height Details", page 5
Vehicle Width	see "Width Details", page 6
Vehicle Weight (UP)	2000 KG
Wheel Load (UP)	500 KG
Vehicle Weight (GP)	3000 KG
Wheel Load (GP)	750 KG
Vehicle Types	Saloon, Estate, SUV, Van

The overall vehicle height including roof luggage rails and antenna mounts must not exceed the max. vehicle height dimensions specified!

UP: Upper-Level Platform | GP: Ground-Level Platform

☐ The following car heights shared as a guide to help you to select the platform distance and construction dimensions:

Volkswagen Golf	149 cm
Volkswagen Tiguan	167 cm
Volkswagen T-Roc	160 cm
Volkswagen T-Cross	159 cm
Volkswagen Passat	152 cm
Dacia Sandero	150 cm
Dacia Duster	170 cm
Renault Clio	145 cm
Renault Captur	158 cm
Fiat/Abarth 500	150 cm
Fiat Panda	156 cm

Tesla Model 3	145 cm
Tesla Model X	169 cm
Ford Kuga	169 cm
Ford Puma	156 cm
Mercedes A-Class	146 cm
Mercedes G-Class	198 cm
Mini Hatch	145 cm
Hyundai Kona	156 cm
Opel/Vauxhall Corsa	149 cm
Volvo XC40	166 cm
Skoda Octavia	147 cm
Hyundai Tucson	167 cm

Peugeot 208	146 cm
Peugeot 2008	155 cm
Peugeot 3008	163 cm
Toyota Corolla	144 cm
Toyota Yaris	151 cm
Toyota RAV4	169 cm
Toyota Camry	145 cm
Citroen C3	161 cm
Porsche Macan	163 cm
Porsche Cayenne	168 cm
BMW 3-Series	143 cm
BMW iX	170 cm
BMW X5	175 cm
Volvo XC 90	178 cm
Land Rover Discovery	189 cm
Land Rover Range Sport	180 cm

All vehicle heights may vary due to the wide range of models and manufacturing year.

HEIGHT DETAILS

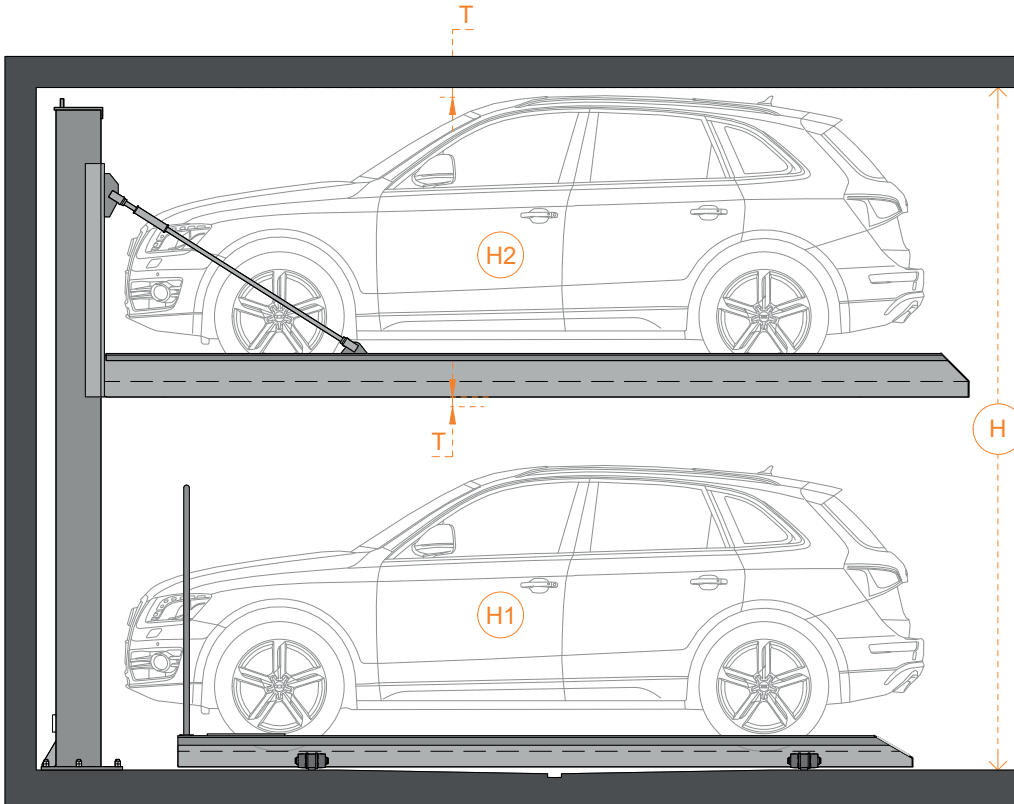

- The Left and top parts of the table below indicate a vehicle height at the lower level and upper levels. Various combinations of these dimensions determine the total clear height. Various versions are available upon request so please contact to have technical support if it is necessary.
- It is recommended that Ground Level Vehicle Height (**H1**) should be higher than an average human height for drivers to conveniently get out of the vehicle.
- Clearance height (**T**) between vehicle and ceiling shall be minimum 5 cm. The clearance height is included to the following table.

		Upper-Level Vehicle Height (H2)											Required Clearance Height (H)	
		150	155	160	165	170	175	180	185	190	195	200		205
Ground Level Vehicle Height (H1)	150	330	335	340	345	350	355	360	365	370	375	380	385	
	155	335	340	345	350	355	360	365	370	375	380	385	390	
	160	340	345	350	355	360	365	370	375	380	385	390	395	
	165	345	350	355	360	365	370	375	380	385	390	395	400	
	170	350	355	360	365	370	375	380	385	390	395	400	405	
	175	355	360	365	370	375	380	385	390	395	400	405	410	
	180	360	365	370	375	380	385	390	395	400	405	410	415	
	185	365	370	375	380	385	390	395	400	405	410	415	420	
	190	370	375	380	385	390	395	400	405	410	415	420	425	
	195	375	380	385	390	395	400	405	410	415	420	425	430	
	200	380	385	390	390	400	405	410	415	420	425	430	435	
205	385	390	395	400	405	410	415	420	425	430	435	440		

All dimensions are given in cm.

WIDTH DETAILS

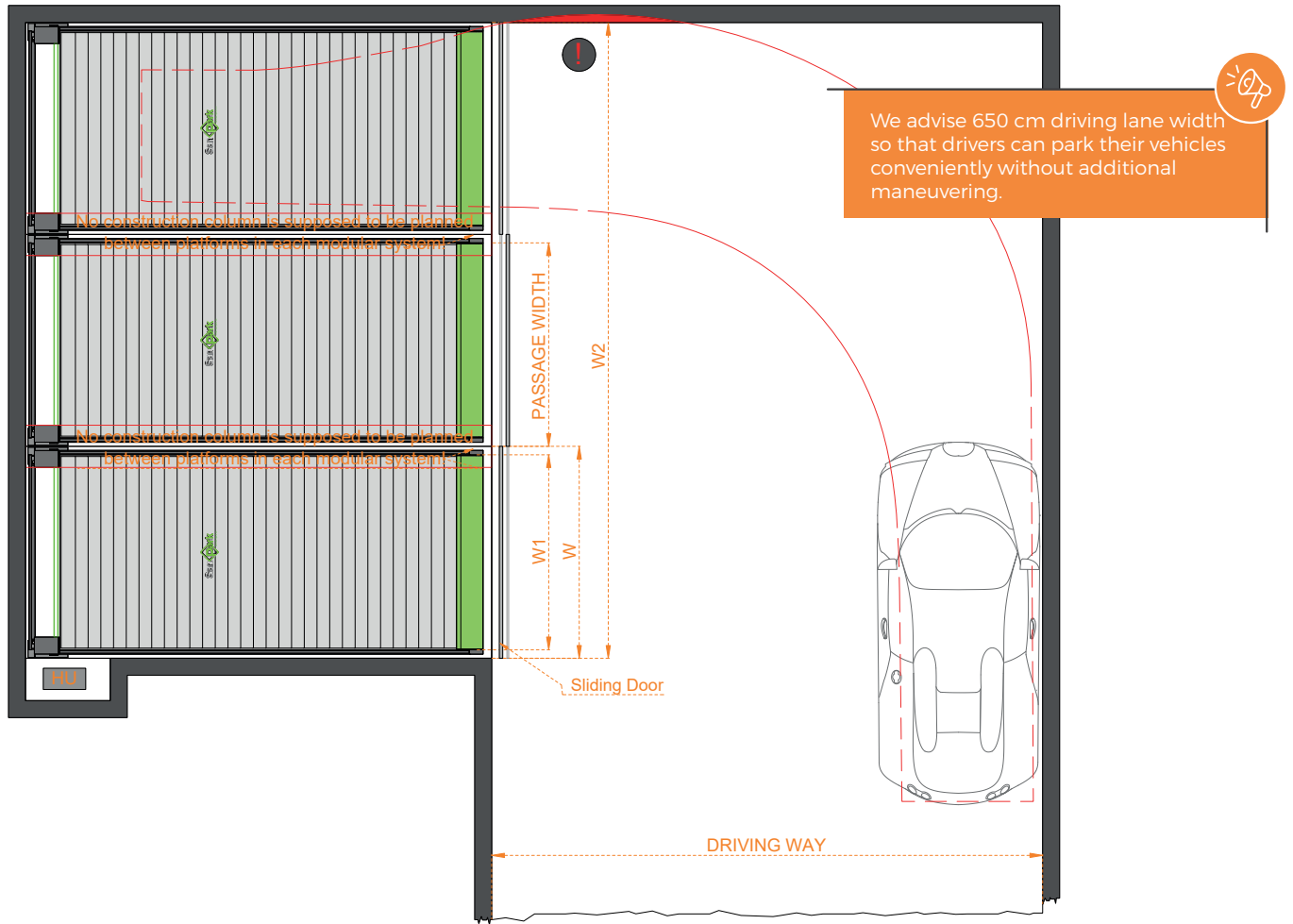

□ The following figures demonstrate the required width for parking areas and their correspondence to clear platform width.

PRACTICAPARK	Installation Width (W)	Upper Level Clear Platform Width (W1)
	250 cm	230 cm
	260 cm	240 cm
	270 cm	250 cm

PRACTICAPARK MODULES AND OVERALL WIDTHS (W2)

Installation Width (W)	2 MODULES	3 MODULES	4 MODULES	5 MODULES	6 MODULES	7 MODULES	8 MODULES	9 MODULES	10 MODULES
250	500	750	1000	1250	1500	1750	2000	2250	2500
260	520	780	1040	1300	1560	1820	2080	2340	2600
270	540	810	1080	1350	1620	1890	2160	2430	2700
280	560	840	1120	1400	1680	1960	2240	2520	2800

PRACTICAPARK MODULES AND THEIR CORRESPONDING VEHICLE CAPACITIES

MODULES	2 MODULES	3 MODULES	4 MODULES	5 MODULES	6 MOD- ULES	7 MODULES	8 MODULES	9 MODULES	10 MODULES
CAR CAPACITY	3 VEHICLES	5 VEHICLES	7 VEHICLES	9 VEHICLES	11 VEHICLES	13 VEHICLES	15 VEHICLES	17 VEHICLES	19 VEHICLES

- **HU** indicates a hydraulic power pack and its length is 50 cm and its width is 25 cm. Its overall height can vary between 50 cm – 60 cm.
- The minimum clear platform width is 205 centimeters for a limited space. We recommend 230 centimeters for convenient parking.
- No construction column is supposed to be planned between platforms in each modular system! The reason is ground floor platforms moves vertically to sides and any columns will block the way of the platform's movement.
- The passage width between two columns of the building cannot be less than the clear platform width.
- While planning Practicapark next to a wall, it is significant to take into consideration that turning the vehicle in one maneuver may cause a crash so please take advice from Sanpark in a such situation, shown in the illustration above.
- While setting driving lane width, please check local regulations. We advise 650 cm driving lane width so that drivers can park their vehicles conveniently without additional maneuvering. The deriving lane width can be reduced according to the project needs but this reduction may lead additional maneuvering. Please request a consultation for planning the project.

Reducing parking width lowers parking comfort according to the vehicle width, vehicle type, and individual driving style.

ELECTRICITY INSTALLATION DIAGRAM

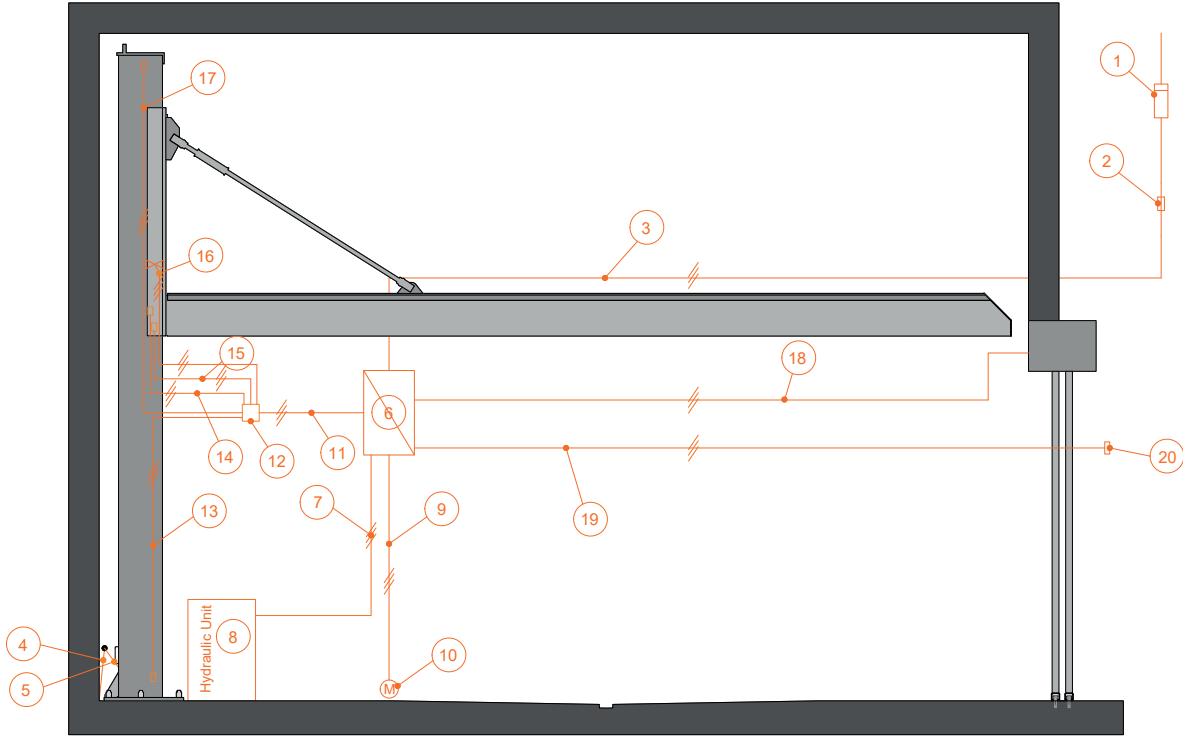

- During installation, it is required to appropriately connect electrical components with the wiring diagram supplied by the manufacturer in accordance with local regulations.

ELECTRICAL DETAILS (In the customer responsibility)

NUMBER	QUANTITY	DEFINITION	FREQUENCY
1	1	Electricity meter	
2	1	3x Safety fuse 32 A circuit breaker 3x 32 A	1 x per unit
3	1	Supply line 5x6 mm ² with marked wire and protective conductor	1 x per unit
4	1	Foundation Earth Connection (distance between grounding max. 10m)	
5	1	Equipotential bonding in accordance with DIN EN 60204 grounding of the steel structure is necessary. provided by the customer	1 x per system

ELECTRICAL DETAILS (In Sanpark responsibility)

NUMBER	DEFINITION	FREQUENCY
6	Distributor Board with main switch	
7	Supply line 4x2,5 mm ² with marked wire and protective conductor	
8	Hydraulic Unit 5.5 kW, 3 Phase current, 380 V 50 HZ	
9	Supply line 6x1,5 mm ² with marked wire and protective conductor	1 x per ground level platform
10	Motor 0.75 kW, 3 Phase current, 380 V 50 HZ	1 x per ground level platform
11	Supply line 12x1 mm ² with marked wire and protective conductor	1 x per module
12	Terminal box	1 x per module
13	Supply line 2x0,75 mm ² with marked wire and protective conductor for limit switch	
14	Supply line 2x0,75 mm ² with marked wire and protective conductor for limit switch	
15	Supply line 2x1,5 mm ² with marked wire and protective conductor for mechanical lock	
16	Control line 2x0,75 mm ²	
17	Field sensor supply line (depends on sensor brand)	
18	Supply line 2x1,5 mm ² with marked wire and protective conductor for sliding door	
19	Supply line 7x1 mm ² with marked wire and protective conductor and CAT 6 Ethernet cable for the control panel	
20	Control Panel and emergency button	

LOADS AND CONSTRUCTION DETAILS

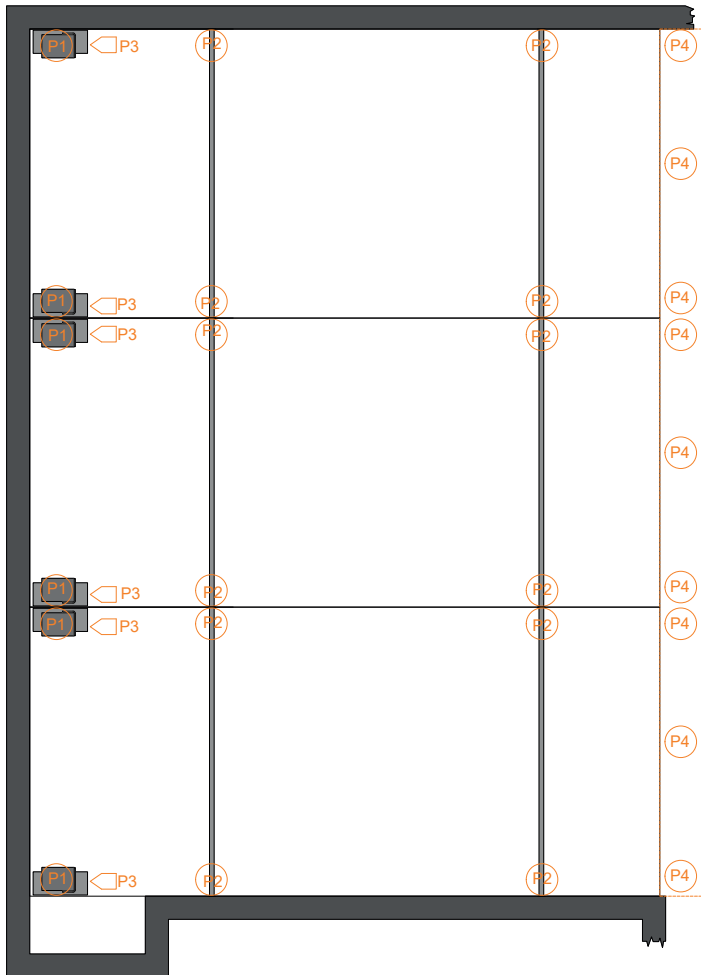
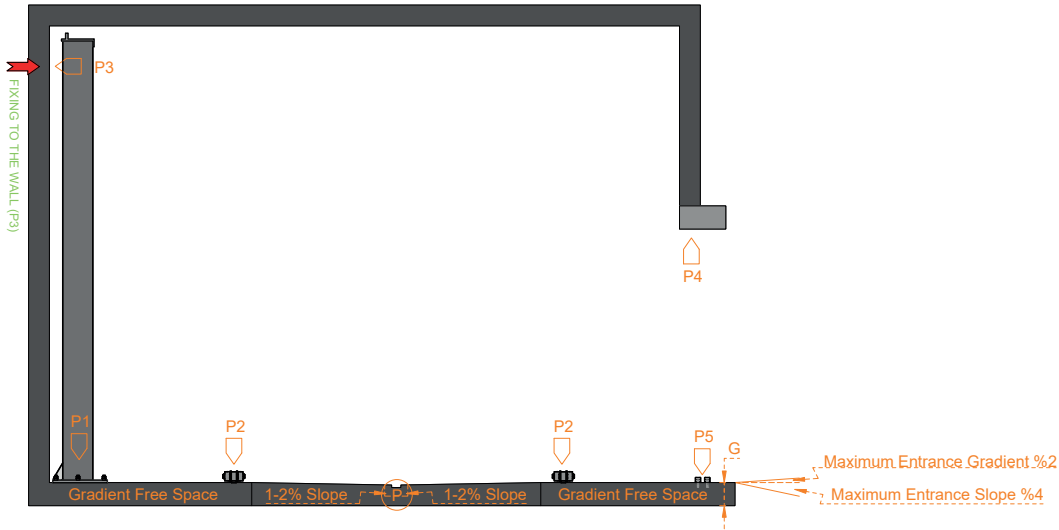

- The systems are anchored into the ground. The drill hole depth in the floor plate is approx. 15 cm, on the walls approx. 10 cm.
- **P4** and **P5** are related to the door load, please see "Sliding Door Details", page x.
- Gradient free space indicates an area where shall be %0 of downward or upward gradient. To have more details, please see "Length Details", page x.
- Concrete quality according to the static requirements of the building. However, we require a slab thickness (**G**) minimum of 20 cm and a concrete quality of min. C20/25 to anchor the system.
- Maximum gradient and slope details are specified in the illustrations above. Improper layout causes extreme difficulties and Sanpark does not accept any responsibilities.
- It is our customer responsibility to plan drainage space on the space shown in the picture as (**P**).

STRUCTURAL FORCES (kN)				
P1	P2	P3	P4	P5
± 20.3	± 10.7	± 4.1	± 1	± 0.2

SLIDING DOOR DETAILS

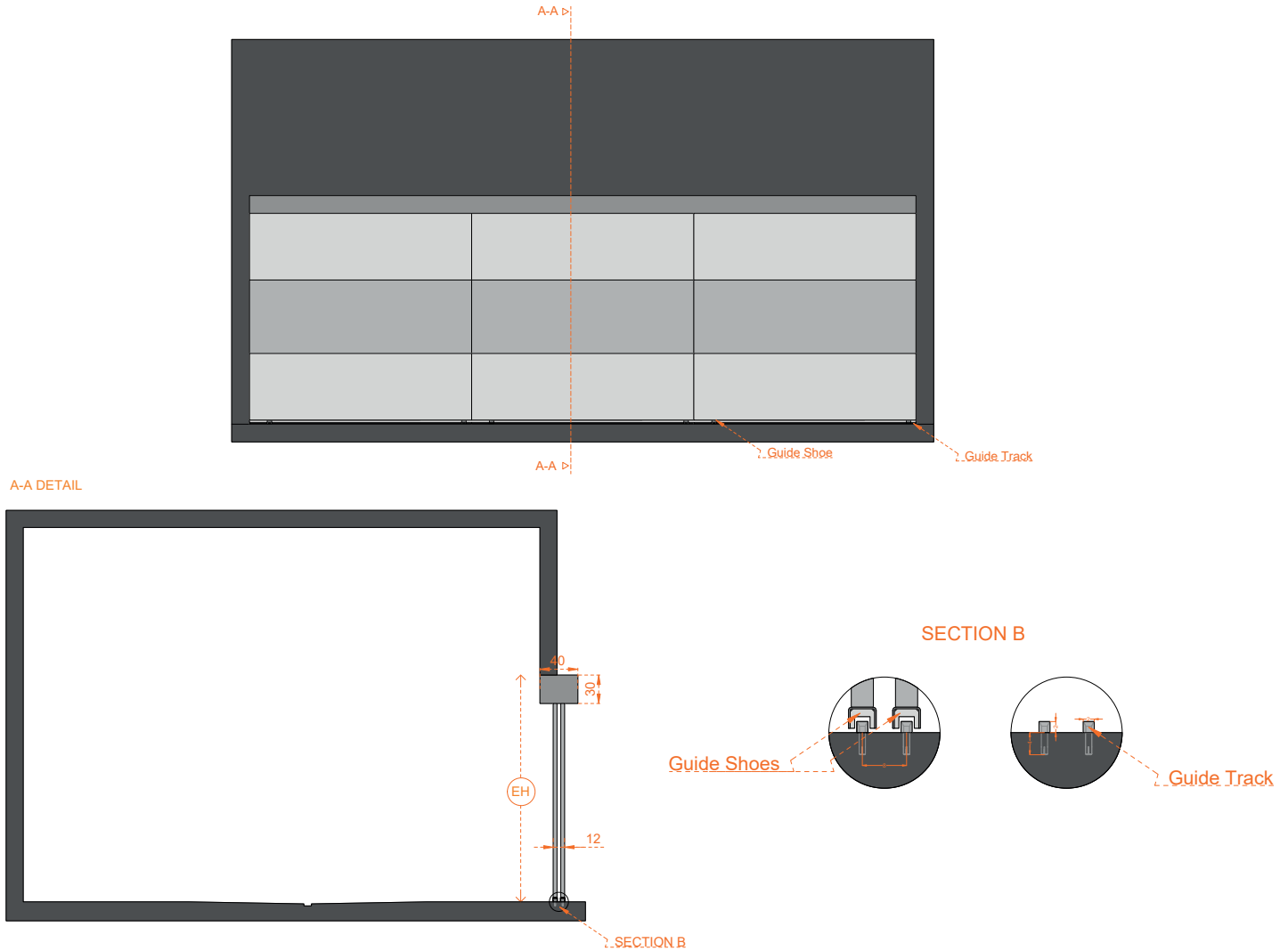

- According to DIN 18202-Table 3-Line 3, the evenness of the floor must not exceed 2 cm. In case of not meeting the condition, the customer needs to level the floor.
- The following figures provides the required entrance height for each vehicle height.
- The guide track is anchored into the ground. The drill hole depth on the floor is approx. 4 cm.

Entrance Height (H)	Vehicle Heights											
	150	155	160	165	170	175	180	185	190	195	200	205
	185	190	195	200	205	210	215	220	225	230	235	240

GROUND FLOOR PLATFORM GUIDE TRACK DETAILS

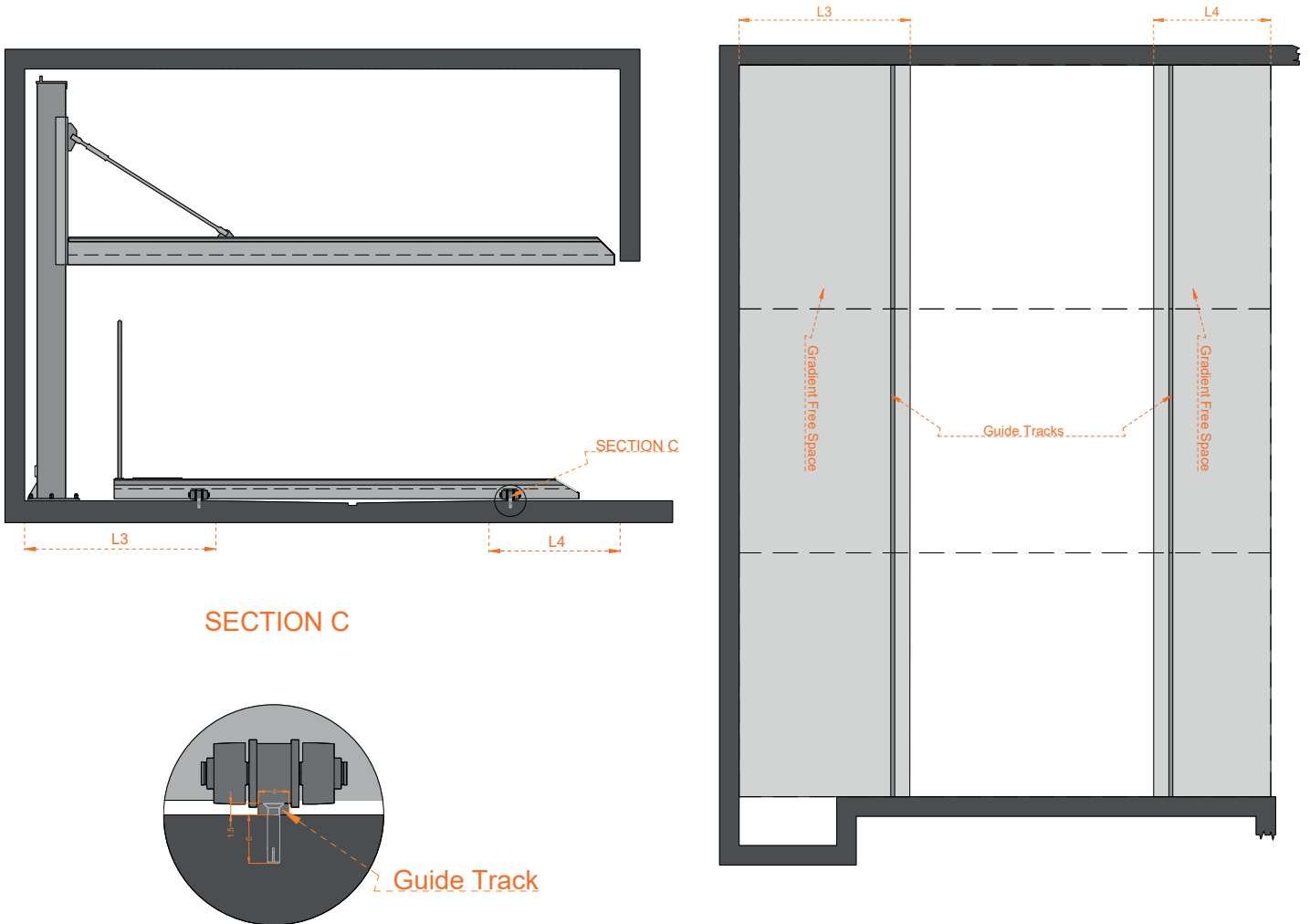

- ▣ Gradient free space (**L3 and L4**) indicates an area where shall be %0 of downward or upward gradient.
- ▣ According to DIN 18202-Table 3-Line 3, the evenness of the floor must not exceed 2 cm. In case of not meeting the condition, the customer needs to level the floor.
- ▣ The guide tracks for platforms are anchored into the ground. The drill hole depth on the floor is approx. 6 cm.
- ▣ The required length (**L1**) varies please see "Length Details", page 3.
- ▣ The system shall not be installed on asphalt. In such cases, DIN 18202-Table 3 Line 3 will not be met. Resulting, improper installation and problems with smooth performance of the system.

Slope Free Space (L3)	Slope Free Space (L4)
145 cm	125 cm
145 cm	135 cm
145 cm	145 cm
145 cm	155 cm

FUNCTION

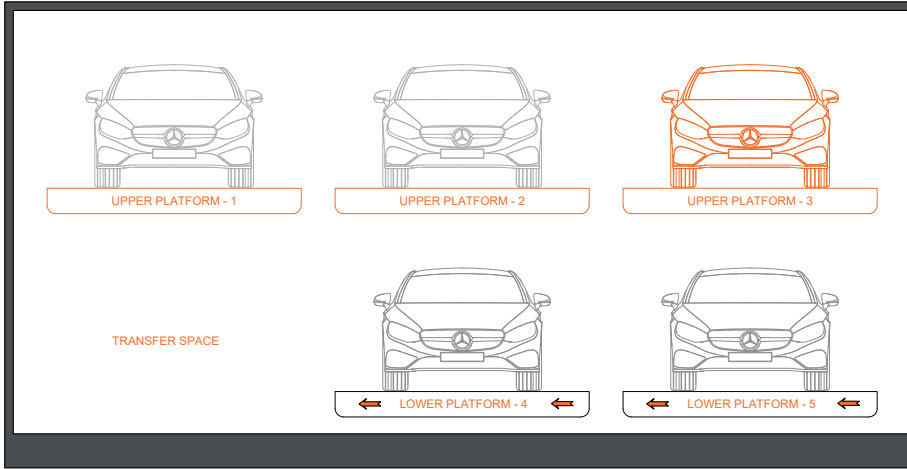

1. Lower platforms can move to sides.
2. If you retrieve the car on the Platform-3, the system moves the lower platforms to the left.

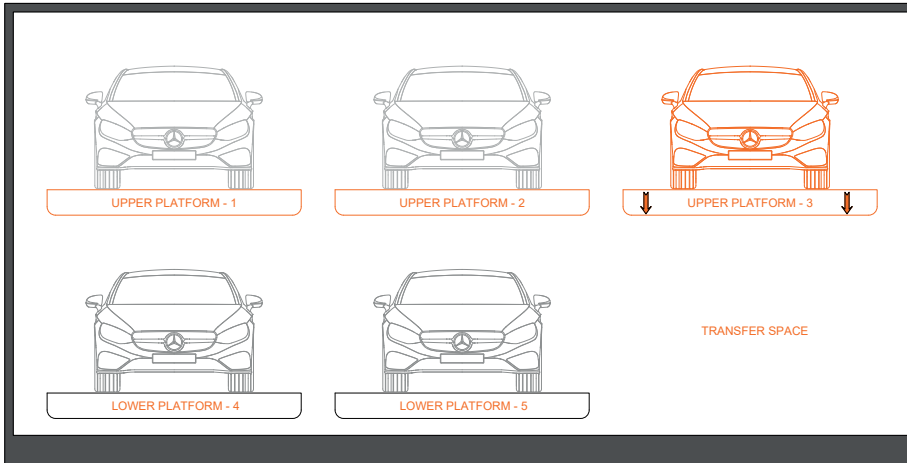

3. Upper platforms can only move up and down.
4. Since there is a transfer space under the Platform-3, the system lowers the Platform-3.

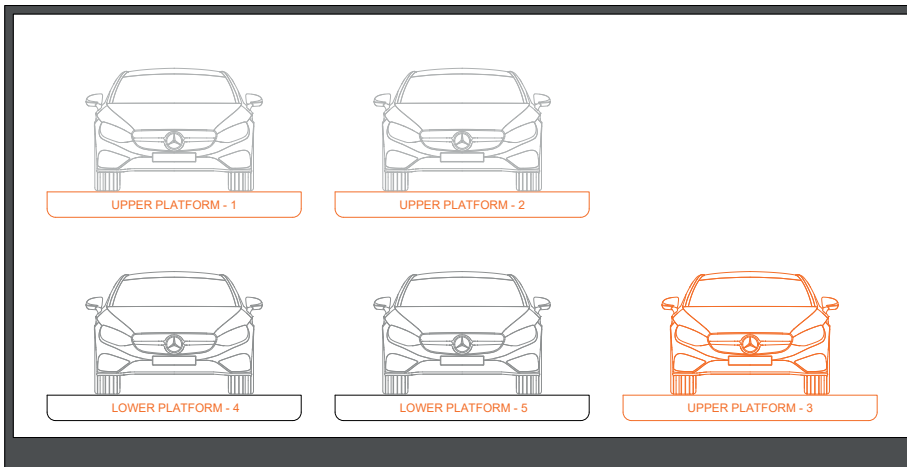

5. The car on the Platform 3 is ready to be park out.

TECHNICAL INFORMATION



Hydraulic Unit

Each Practicapark has one hydraulic unit. Please request a consultation for planning the project.



Temperature

Practicapark is designed to operate between -15° and +40°C at atmospheric humidity of 50 percent. If the local temperature is different from the above, please consult Sanpark.



Conformity Test

All our systems comply with EC machinery directive 2006/42/EC and TS/EN 14010:2009 +A1:2009.



Building application documents

All our systems generally require local approval. Please observe local regulations.



Maintenance

Regular maintenance by qualified personnel can be provided by an Annual Service Contract.



Care and Corrosion Protection

Due to the corrosion danger, apart from regular maintenance, all our galvanized equipment and platforms must be regularly cleaned up salt water, dirt, leak, any chemical substance, and sand. The garage and pits must be always ventilated well.



Railings

If passageways are directly next to the systems, railings have to be provided according to TS EN ISO 13857 by the client according to local requirements, height min. 200 cm.



Fire Safety

All fire safety requirement(s) and all possible mandatory item(s) and equipment(s) must comply with local regulations and must be provided by the customer.



Noise Protection

In compliance with DIN 4109-1 Noise protection: Maximum sound pressure level in living and sleeping areas 30 dB (A).

User noise like accessing the platform, the slamming of vehicle doors, the vehicle's engine, and brake noise are not subject to the requirements.

In order to provide 30 dB (A) in rooms the following conditions are required:

Additional Sanpark noise protection package according to quote.

Insulation figure of the construction of min R'w= 57 dB (in the customer's responsibility)

Walls that are close to the parking systems must be done as a single wall and deflection resistant with min. m'= 300 kg/m2 (in the customer's responsibility)

The solid ceiling above the parking systems with min. m'= 400 kg/m2 (in the customer's responsibility)

At differing constructional conditions, additional sound-absorbing methods are in the customer's responsibility.



Alterations and/or Modifications

Sanpark's engineering department is constantly challenging itself to improve its systems. In the event of technological advancement, Sanpark can adopt newer or different technologies, systems, or standards to improve overall quality.

SERVICES TO BE PROVIDED BY THE CUSTOMER



Barriers

In accordance with DIN EN 13857, barriers may be required in case of passageways in front of, behind, or next to the systems.



Parking Space Numbering

Numbering the parking spaces.



Lighting

It is in the customer's responsibility to check local regulations regarding the illumination of parking spaces.



Conduits and Wall Openings

Any conduit and wall opening work belongs to the customer, yet Sanpark can assist during the planning phase in such cases. Please consult Sanpark if necessary.



Supply Cable to Master Switch

The customer must run the supply cable to the master switch during assembly.



Drainage

For environmental protection, we advise applying coating the pit floor. Oil and/or fuel separators should be installed in accordance with local regulations. To drain large quantities of water from the yard, the customer must install a water collection channel around the system.



Earth Foundation

The customer must earth the steel structure with a foundation earth connection and lay equipotential bonding according to local regulations.

CERTIFICATES



UYGUNLUK ONAYI ATTESTATION OF CONFORMITY

Sertifika Numarası / Certificate Number : AVA-CE/011124.12.2020

Üretici / Manufacturer : ŞANMAK MAKİNA SAN. VE TİC. A.Ş.

Üretici Adresi / Manufacturer Address : ÇALI SANAYİ BÖLGESİ 6. SOK. NO:8 NİLÜFER / BURSA / TÜRKİYE

Ürün Tanımı / Product Description : MULTI-STORY, SEQUENTIAL, VERTICAL AND HORIZONTAL MOVEMENT, HYDRAULIC DRIVE, SEMI-AUTOMATIC CAR PARKING LIFT, ÇOK KATLI, SIKALI DIKEY VE VATAF YÖNDE HAREKETLİ, HİDROLİK TAHRİKLİ, YARI OTOMATİK OTOPARK LİFTİ

Tip/Model / Type/Model : PRACTICA, SLIDER, PRACTICA UN, PRACTICA ML, PRACTICA TRIO, PRACTICA CL

İlgili Yönetmelikler / Related Directives : MAKİNE EMNİYETİ YÖNETMELİĞİ 2006/42/AT EK VIII
MACHINE SAFETY DIRECTIVE 2006/42/EC Annex VIII



İlgili Standartlar / Related Standards : EN ISO 12100, EN ISO 4413, TS EN 14120+A1, EN ISO 13849-1,
EN 60204-1, EN 14010+A1

Test Raporu / Test Report : ST.1039.03

AVACERT adı ve adresi yukarıda belirtilen firmamızın sunduğu teknik dokümanları inceleyerek, belirtilen ürünün Makina Emniyeti Yönetmeliği 2006/42/AT Ek VIII kurallarına uygunluğunu onaylar. Yukarıda belirtilen üründeki ürün üzerine CE işaretini, üreticinin kendisi sorumluluğunda hazırlayacağı AT Uygunluk Beyanı ile bitirir. İncelemeye alınan ürüne ait olan bu belge tasarrufla değiştirilmeden geçerliliğini yitirmez. Bu belgenin geçerliliğini www.avacert.com internet sayfasından kontrol edebilirsiniz. Bu belge sadece yukarıda adı geçen ürün tip/modelleri için geçerlidir. Yukarıda adı geçen firma ve AVACERT bu belgelerin bir kopyasını tescil tarihinden itibaren 15 yıl süreyle muhafaza etmelidir. Bu belgenin mülkiyeti hakkı AVACERT'e aittir ve istenildiğinde iade edilmelidir.

AVACERT examines the technical documents submitted by the company whose name and address are specified above and approves the conformity of the specified product to the Machinery Safety Regulation 2006/42/EC Annex VIII. It may attach the CE mark on the product of the above types with the EC Declaration of Conformity, which the manufacturer will prepare at his own risk. This document, which belongs to the product being examined, will expire if the design changes. You can check the validity of this document on the website www.avacert.com. This document is valid only for the product types / models mentioned above. The above mentioned firm and AVACERT must keep a copy of these documents for 15 years from the date of registration. The ownership of this document belongs to AVACERT and must be returned upon request.

Yayın Tarihi / Issue Date : 30.12.2020
Geçerlilik Tarihi / Validity Date : 29.12.2022

Avacert International Certification Body
Avacert Anadolu Uluslararası Belgelendirme, Denetim, Teknik Kontrol Eğitim ve Test Hizmetleri LTD. ŞTİ.
www.avacert.com | ce@avacert.com



CERTIFICATE



ŞANMAK MAKİNA SAN. VE TİC. A.Ş.

ÇALI SANAYİ BÖLGESİ 6. SOK. NO:8
NİLÜFER / BURSA / TÜRKİYE

Has been assessed and found to Comply with the Requirements of:
Denetlenmiş ve aşağıdaki standardın gerekliliklerine uygunluğu görülmüştür:

ISO 9001:2015

The Quality Management System is applicable to:
Kalite Yönetim Sistemi:

DESIGN, PRODUCTION AND SERVICE SERVICES OF MACHINES
FOR VEHICLE, LOAD LIFTING AND TRANSPORT

TAŞIT, YÜK KALDIRMA VE TAŞIMA AMAÇLI MAKİNALARIN
TASARIMI, ÜRETİMİ VE SERVİS HİZMETLERİ

Certificate Number: QMS-05807
Belge Numarası: QMS-05807

Initial Certification Date: 15.12.2021
İlk Belgelendirme Tarihi: 15.12.2021

Certification Period: 3 Years
Belgelendirme Periyodu: 3 Yıl

Certificate Validity Date: 14.12.2022
Belge Geçerlilik Tarihi: 14.12.2022





IAS
ACCREDITED
Management Systems
Certification Body
MSCB-135

IQR ULUSLARARASI BELGELENDİRME HİZMETLERİ LTD.ŞTİ.
Beşevler Mah. Kocayunus Sk. No:3 Anadolı Han Plaza K:2 Nilüfer / BURSA
Tel: +90.224.206 00 16 Faks: +90.224.249 41 13 www.iqcert.com e-posta: info@iqcert.com