

1 **SUBLIFT H1W1-W2**

SUBLIFT H1W1-W2

Mechanical parking system for outdoor usage with require a pit.

DATA SHEET



WE
EXPAND
YOUR PARKING
CAPACITY

2 SUBLIFT H1W1-W2

TABLE OF CONTENTS

TABLE OF CONTENTS	2
GENERAL DESCRIPTION	2
LENGTH DETAILS	3
VEHICLE DETAILS, CLEARANCE & DIMENSIONS	4
HEIGHT and DEPTH DETAILS	5
WIDTH DETAILS	6
ELECTRICITY INSTALLATION DIAGRAM	7
LOADS AND CONSTRUCTION DETAILS	8
PIT CONSTRUCTION DETAILS	9
SUBLIFT DRAINAGE DETAILS	11
TECHNICAL INFORMATION	12
SUBLIFT SYSTEM COMPONENTS	13
SERVICES TO BE PROVIDED BY THE CUSTOMER	13
CERTIFICATES	14

GENERAL DESCRIPTION

- ▣ Sublift is an independent parking system for an indoor or outdoor application and it allows 2, 3, 4 vehicles to be parked on top of each other in respect to its types in a parking space that merely allows 1 vehicle under normal conditions.
- ▣ Sublift platforms moves vertically.
- ▣ The height, width and length of the platform can be customized according to the customer's request. (see "Height and Width Details", page 5 and 6).
- ▣ The lifting capacity of the platforms can be customized according to the customer's request. (see "Loads and Construction Details", page 8).
- ▣ The operating key is installed in front of the columns or on the outside.
- ▣ Hot-dip galvanization is applied to the main construction.
- ▣ It is safe and secured with an automatic electromagnetic mechanic position locker.
- ▣ All dimensions are minimum and tolerance for dimensions +3/-0 cm.

LENGTH DETAILS

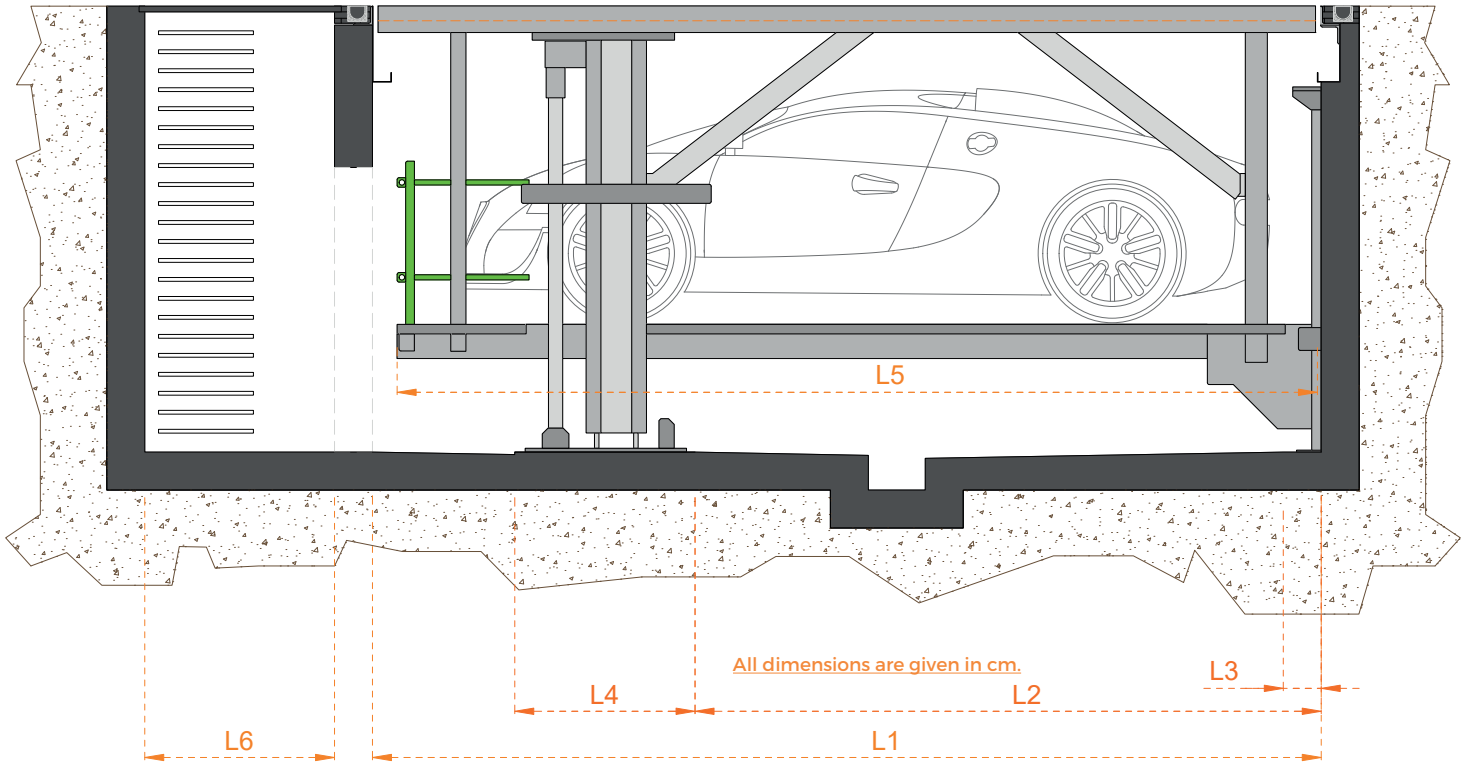

- Maximum vehicle length dimensions can be like the following table. In case of shorter and longer versions, please consult Sanpark.

SUBLIFT LENGTH DIMENSIONS

Maximum Vehicle Length	Platform Length (L5)	Required Space (L1)	Column Position (L2)	Gradient Free Space (L3)	Gradient Free Space (L4)
475 cm	485 cm	500 cm	330 cm	20 cm	95 cm
500 cm	510 cm	525 cm	360 cm	20 cm	95 cm
520 cm	530 cm	550 cm	380 cm	20 cm	95 cm

- The position of the (L4) is determined by the position of the column (L2).
- Ground level pit length is different from the length inside the pit due to drainage channels. Please see "Pit Construction Details", page 9
- Maintenance shaft length (L6) is recommended by Sanpark as a 100 cm.

Operation

With the help of "Hold-to-Run" device which automatically returns to the "off" position after release, Sublift's users securely operate the system.

Independent Parking

All parking spaces and vehicles in the system can be used without blocking one another.

VEHICLE DETAILS, CLEARANCE & DIMENSIONS

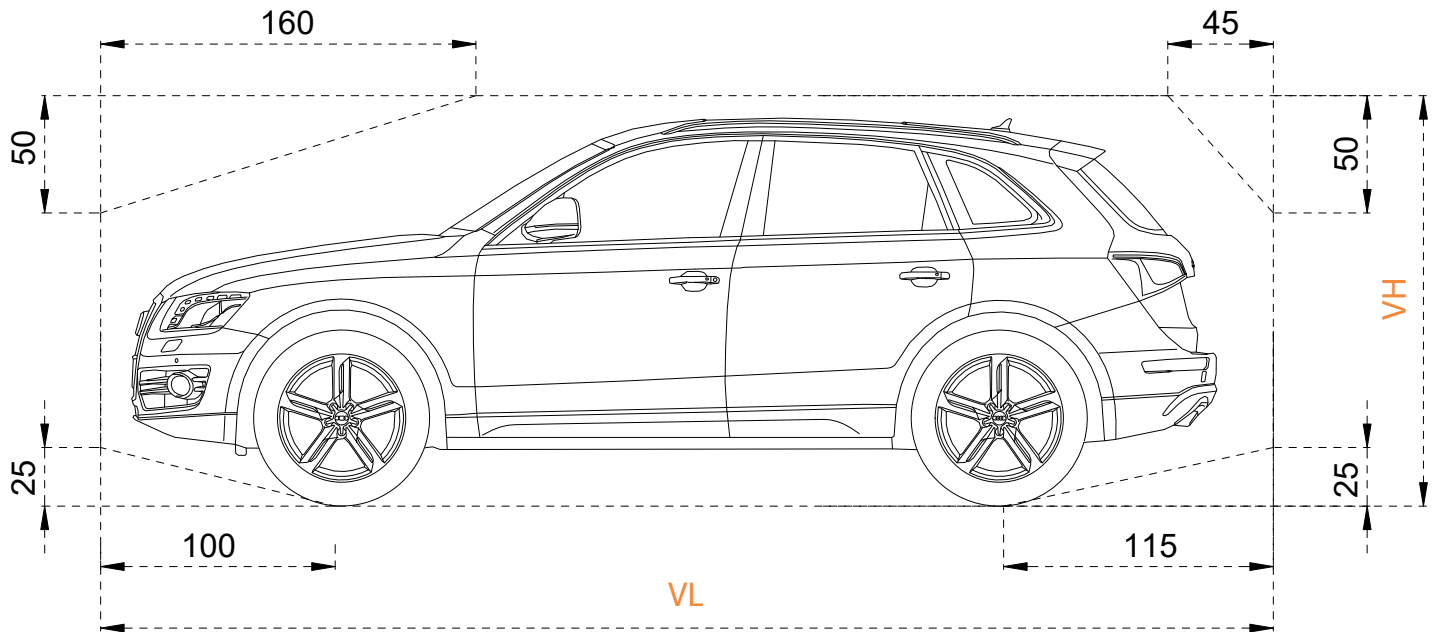

Vehicle Length (VL)	see "Length Details", page 3
Vehicle Height (VH)	see "Height Details", page 5
Vehicle Width	see "Width Details", page 6
Vehicle Weight	see "Loads and Construction Details", page 6
Wheel Load	500 KG or 750 KG
Vehicle Types	Saloon, Estate, SUV, Van

The overall vehicle height including roof luggage rails and antenna mounts must not exceed the max. vehicle height dimensions specified

▣ The following car heights shared as a guide to help you to select the platform distance and construction dimensions;

Volkswagen Golf	149 cm
Volkswagen Tiguan	167 cm
Volkswagen T-Roc	160 cm
Volkswagen T-Cross	159 cm
Volkswagen Passat	152 cm
Dacia Sandero	150 cm
Dacia Duster	170 cm
Renault Clio	145 cm
Renault Captur	158 cm
Fiat/Abarth 500	150 cm
Fiat Panda	156 cm

Tesla Model 3	145 cm
Tesla Model X	169 cm
Ford Kuga	169 cm
Ford Puma	156 cm
Mercedes A-Class	146 cm
Mercedes G-Class	198 cm
Mini Hatch	145 cm
Hyundai Kona	156 cm
Opel/Vauxhall Corsa	149 cm
Volvo XC40	166 cm
Skoda Octavia	147 cm
Hyundai Tucson	167 cm

Peugeot 208	146 cm
Peugeot 2008	155 cm
Peugeot 3008	163 cm
Toyota Corolla	144 cm
Toyota Yaris	151 cm
Toyota RAV4	169 cm
Toyota Camry	145 cm
Citroen C3	161 cm
Porsche Macan	163 cm
Porsche Cayenne	168 cm
BMW 3-Series	143 cm
BMW iX	170 cm
BMW X5	175 cm
Volvo XC 90	178 cm
Land Rover Discovery	189 cm
Land Rover Range Sport	180 cm

All vehicle heights may vary due to the wide range of models and manufacturing year.

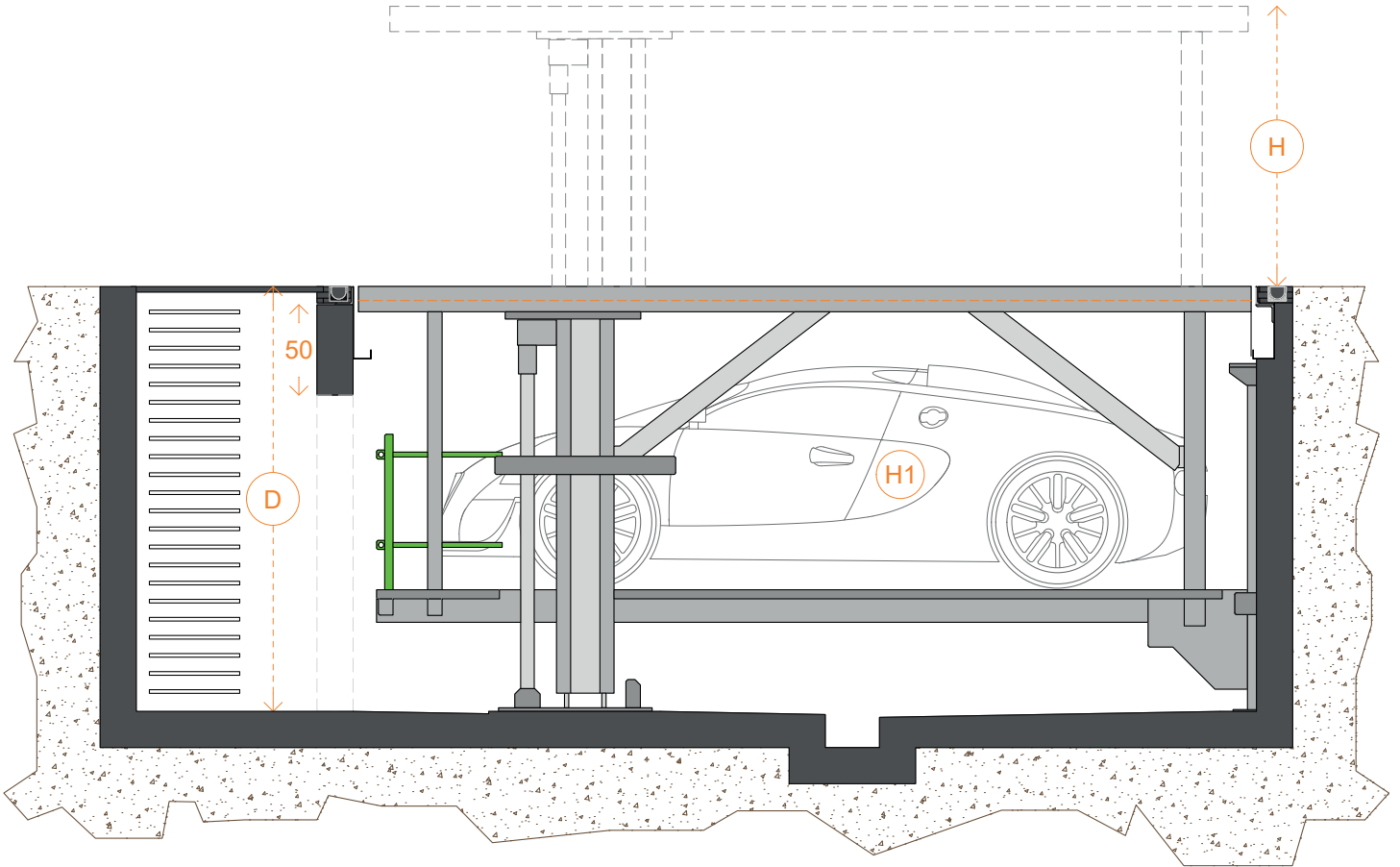
HEIGHT and DEPTH DETAILS

All dimensions are given in cm.

- ▣ The table below indicates vehicle heights (**H1**) and their corresponding operation height (**H**) and their relevant pit depth (**D**). Various versions are available upon request so please contact to have technical support if it is necessary.
- ▣ It is recommended that Vehicle Height (**H1**) should be higher than an average human height for drivers to conveniently get out of the vehicle.
- ▣ To have more details about the pit, please see "Pit Construction Details", page 9

SUBLIFT HEIGHT DIMENSIONS

Car Height (H1)	150 cm	155 cm	160 cm	165 cm	170 cm	175 cm	180 cm	185 cm	190 cm	195 cm	200 cm	205 cm
Height (H)	155 cm	160 cm	165 cm	170 cm	175 cm	180 cm	185 cm	190 cm	195 cm	200 cm	205 cm	210 cm
Pit Depth (D)	245 cm	250 cm	255 cm	260 cm	265 cm	270 cm	275 cm	280 cm	285 cm	290 cm	295 cm	300 cm

WIDTH DIMENSIONS

Mono Platform

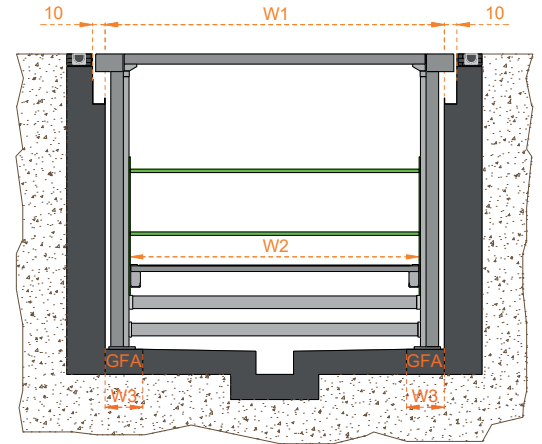
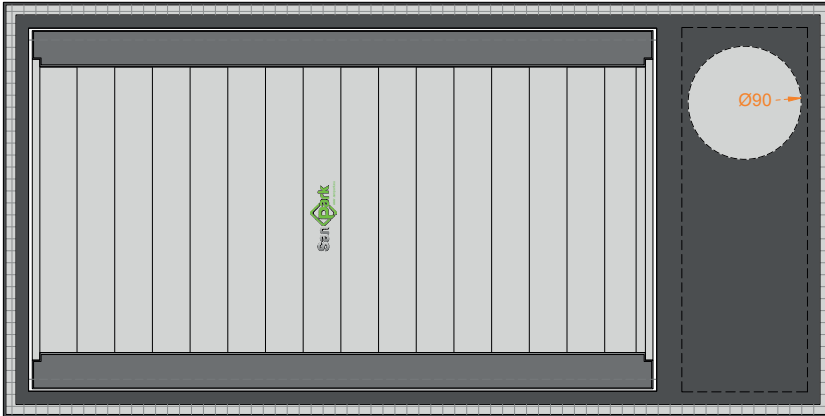

Double Platform

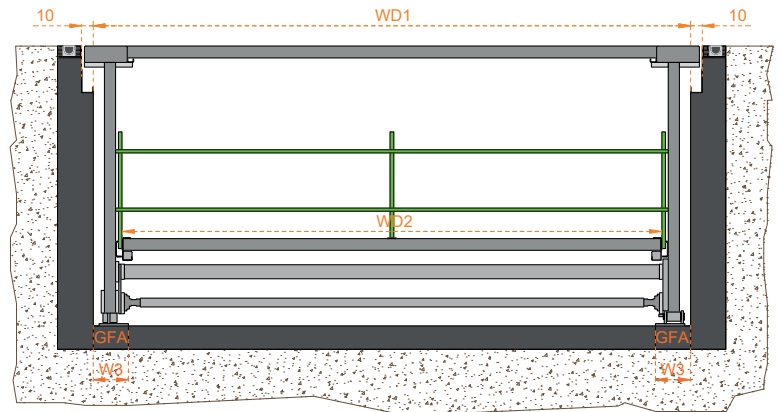
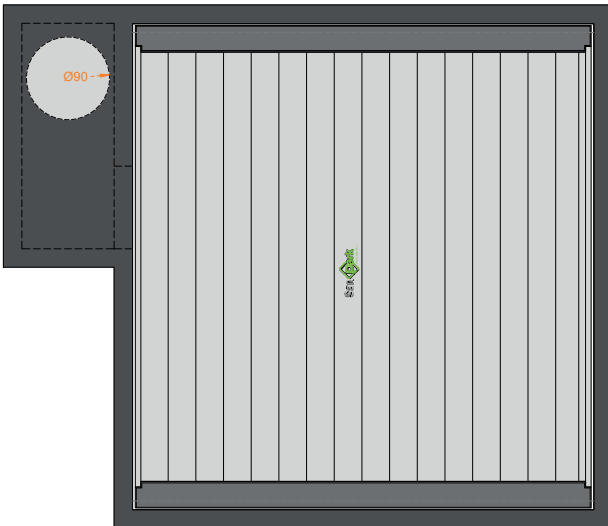

- Gradient free area (GFA) (L3, L4 and W3) indicates a space where shall be no gradient or slope. Construction the pit in accordance with slope directions and gradient free area is performed by the customer.

- The following figures demonstrate the required width for parking areas and their correspondence to clear platform width.

SUBLIFT WIDTH DIMENSIONS

Pit Width (W1)	260 cm	270 cm	280 cm	290 cm
Platform Width (W2)	220 cm	230 cm	240 cm	250 cm
Gradient Free Space Width (W3)	30 cm	30 cm	30 cm	30 cm

SUBLIFT DOUBLE PLATFORM WIDTH DIMENSIONS

Pit Width (WD1)	500 cm	510 cm	520 cm	530 cm
Platform Width (WD2)	450 cm	460 cm	470 cm	480 cm
Gradient Free Space Width (W3)	30 cm	30 cm	30 cm	30 cm

Reducing parking width lowers parking comfort according to the vehicle width, vehicle type, and individual driving style.

- Ground level pit width is different from the width inside the pit due to drainage channels. Please see "Pit Construction Details", page 9.
- We recommend 250 centimeters platform width for mono platform and 500 centimeters platform width for double platform to park conveniently.
- While setting driving lane width, please check local regulations.
- There must be no gradient or slope at Gradient Free Space Width (W3) to install the machine properly.
- The roof also can support one car but it cannot be operated with it for a standard machine. It is possible to operate the machine with the vehicle on the roof with a special design and please consult Sanpark in such cases.

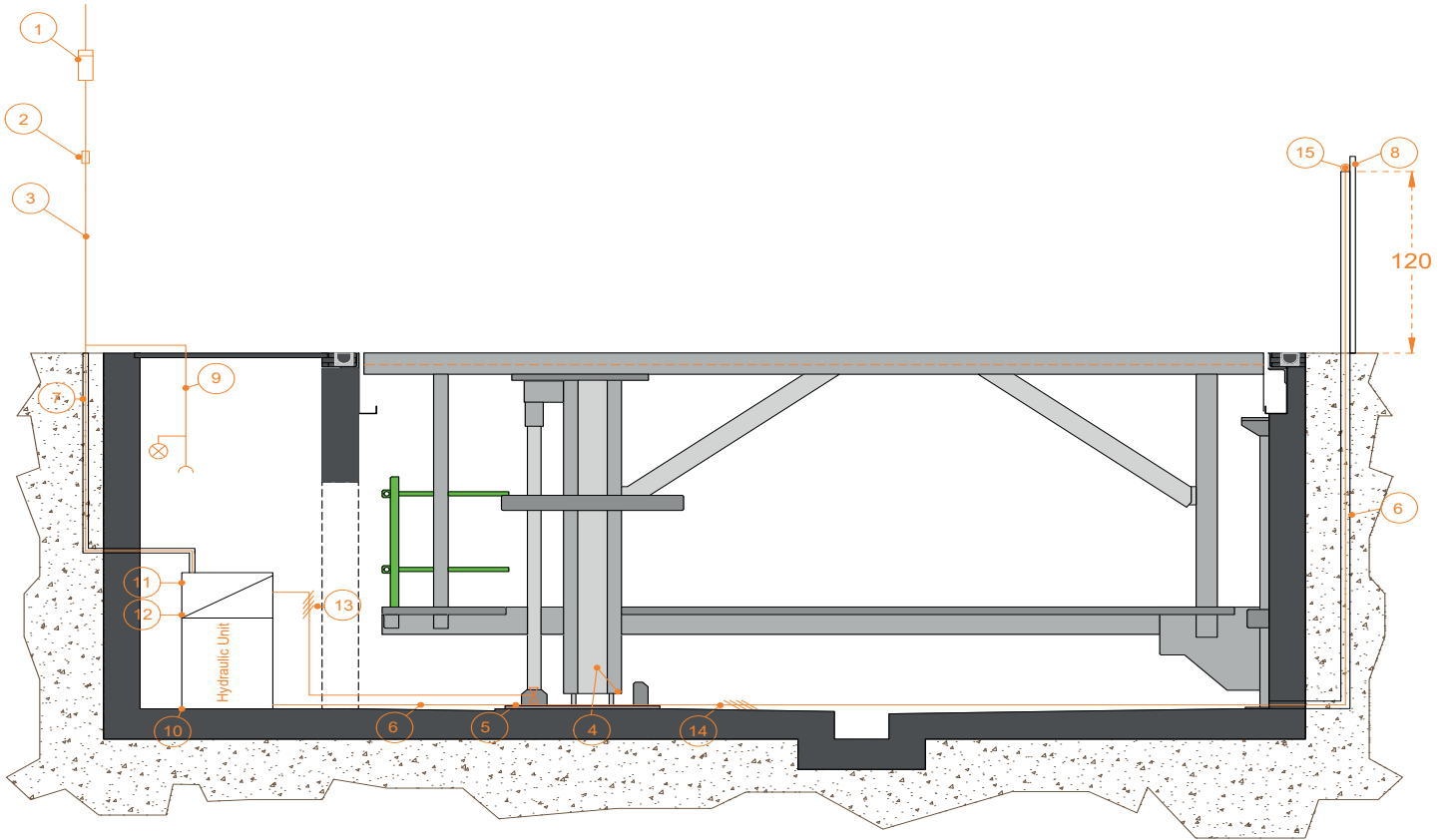
ELECTRICITY INSTALLATION DIAGRAM

- During installation, it is required to appropriately connect electrical components with the wiring diagram supplied by the manufacturer in accordance with local regulations.

ELECTRICAL DETAILS (In the customer responsibility)

NUMBER	QUANTITY	DEFINITION	POSITION	FREQUENCY
1	1	Electricity meter	in the supply cable	
2	1	3x Safety fuse 32 & Circuit Breaker 3x 40A (Trip Characteristic C)	in the supply cable	1 x per unit
3	1	Supply cable 5x4 mm ² (3 PH+PE) or PLC type (3PH+N+PE) with marked wires and protective earth	supply cables to the main switch	1 x per unit
4	Every 10 m	Foundation Earth Connection	Corner or middle of pit floor	
5	1	Equipotential bonding in accordance with DIN EN 60204 grounding from foundation earth connection to system		1 x per system
6	1	Empty pipe EN 40 (M40) with taut wire	from pit floor to operating device	1 x per unit
7	1	Empty pipe EN 50 (M50) with taut wire	supply cable to hydraulic unit	
8	1	Operation Device Base		
9	1	Separate supply cable 230V with lighting and socket	from the electricity meter in the maintenance shaft	

ELECTRICAL DETAILS (In Sanpark responsibility)

NUMBER	DEFINITION
10	Hydraulic Unit 5.5 Kw, 3 Phase current, 230/400V 50HZ
11	Switch cabinet with lockable master switch
12	Control cable 4x2.5 mm ² with marked wires and protective earth
13	Control cable 2x0.75 mm ² with marked wires and protective earth
14	Control cable 7x1 mm ² with marked wires and protective earth
15	Operating Device

LOADS AND CONSTRUCTION DETAILS

- The systems are anchored into the ground. The drill hole depth in the floor plate is approx. 14 cm, in the walls approx. 10 cm. If the precise figures are required, please consult Sanpark.
- Concrete quality according to the static requirements of the building. However, we require a slab thickness (G) minimum of 20 cm and a concrete quality of min. C20/25 to anchor the system.

		MONO PLATFORM STRUCTURAL FORCES (kN)				
		P1	P2	P3	P4	P5
CAR WEIGHT	2000 KG	± 39	± 7	± 12	± 18	± 8
	2600 KG	± 45	± 8	± 14	± 21	± 9
	3000 KG	± 52	± 9	± 15	± 22	± 10

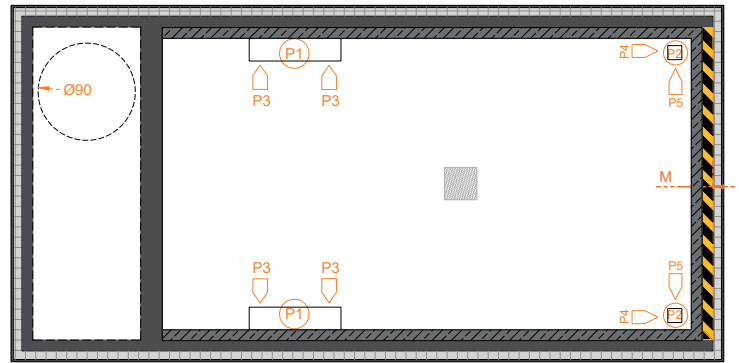
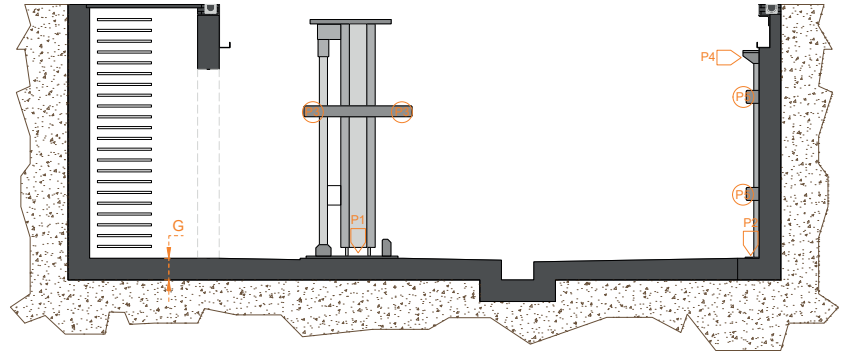

- The systems are anchored into the ground. The drill hole depth in the floor plate is approx. 15 cm, in the walls approx. 12 cm. If the precise figures are required, please consult Sanpark.
- Concrete quality according to the static requirements of the building. However, we require a slab thickness (G) minimum of 20 cm and a concrete quality of min. C25/30 to anchor the system.
- Standard lifting capacity is 2000 kg but it is also possible to increase the capacity to 2600 kg and 3000 kg. In case of further capacity, please consult Sanpark.
- According to DIN EN 14010, the floor has to be marked with 10 cm wide yellow-black stripes (M) to point out the dangerous area. The marking must comply with ISO 3864.

		DUO PLATFORM STRUCTURAL FORCES (kN)				
		P1	P2	P3	P4	P5
CAR WEIGHT	2000 KG	± 75	± 13	± 23	± 34	± 15
	2600 KG	± 86	± 15	± 25	± 35	± 16
	3000 KG	± 99	± 17	± 27	± 37	± 17

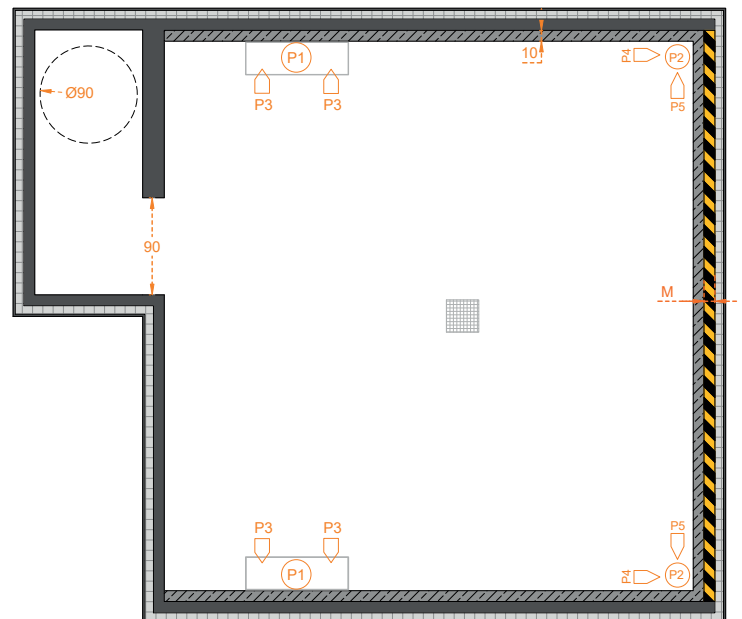

PIT CONSTRUCTION DETAILS

Mono Platform

Top View

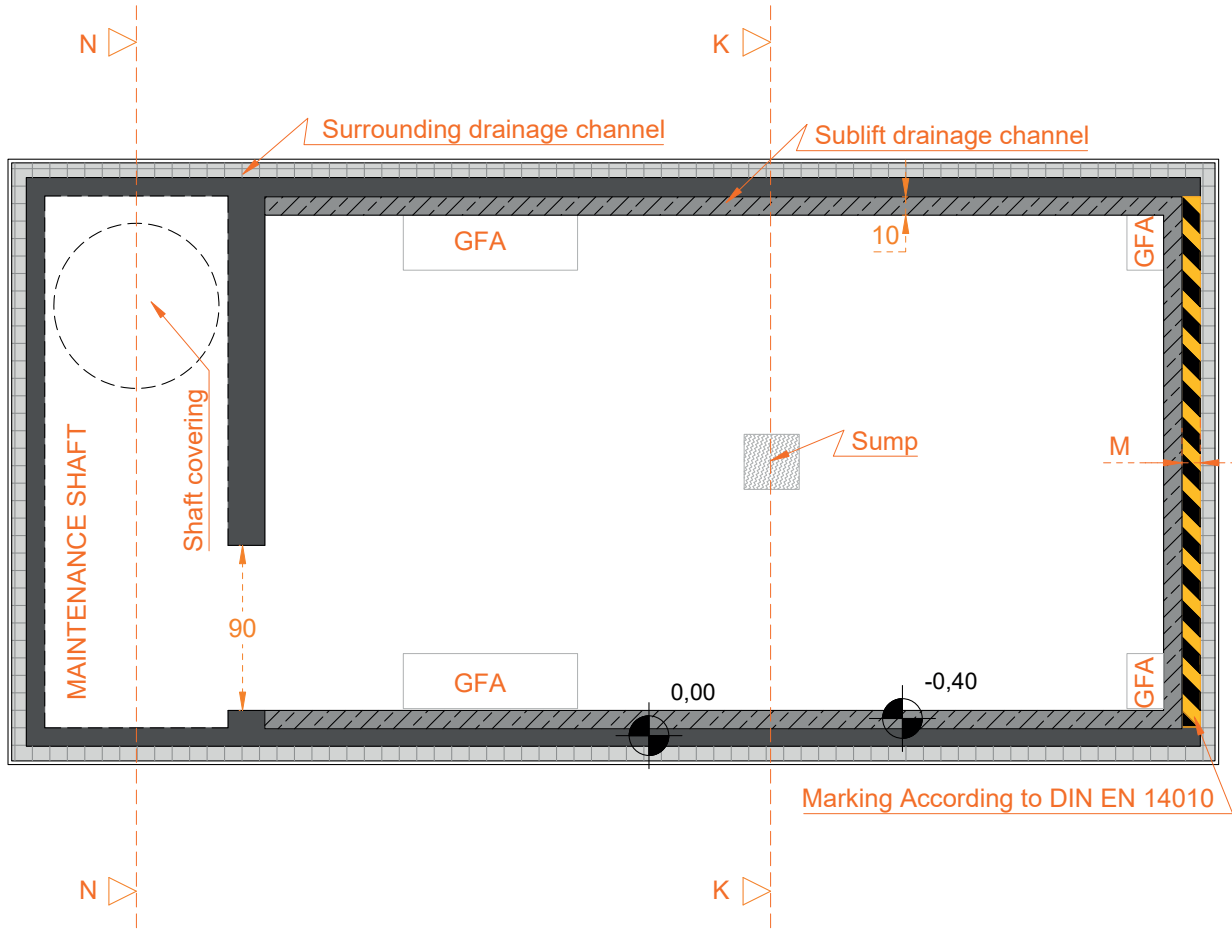

Front Pit View

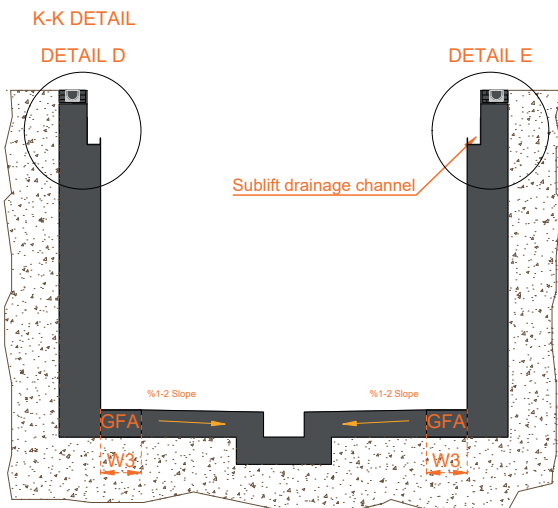

Front Maintenance Shaft

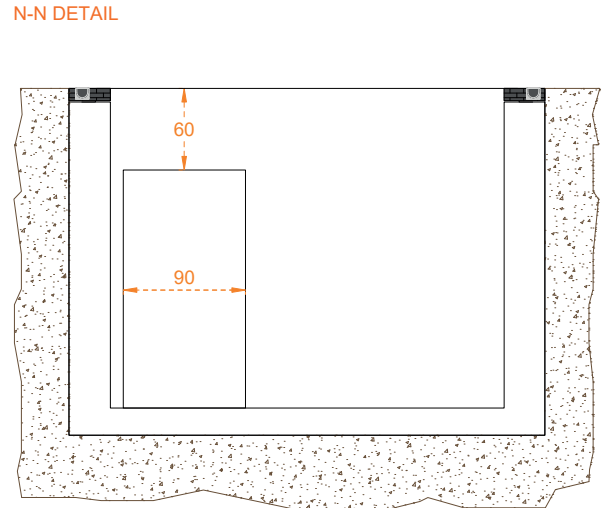

- Detail A, Detail B, Detail C, Detail D, and Detail E can be closely examined at the following details in this article. Please check proper detail sections above before designing the pit. To see 3D Construction view, please see page 9.

Duo Platform

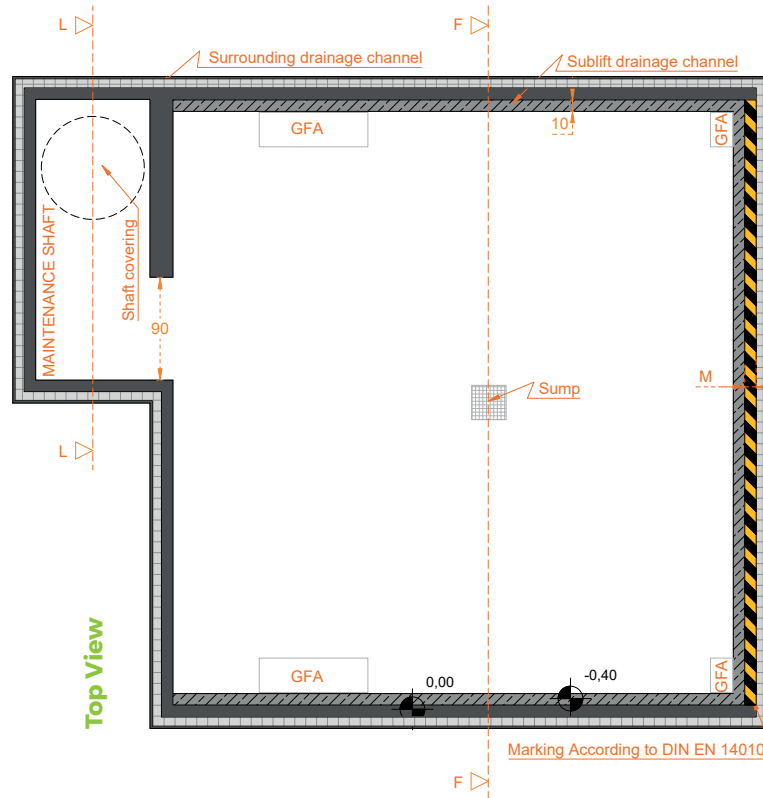

Top View

L-L DETAIL

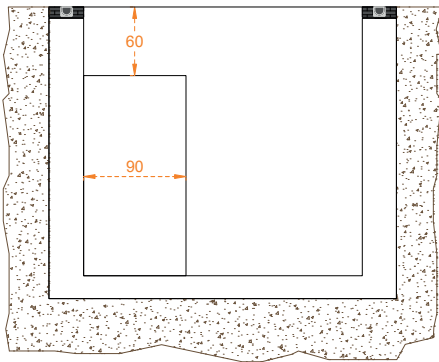

Front Maintenance Shaft

F-F DETAIL
DETAIL D

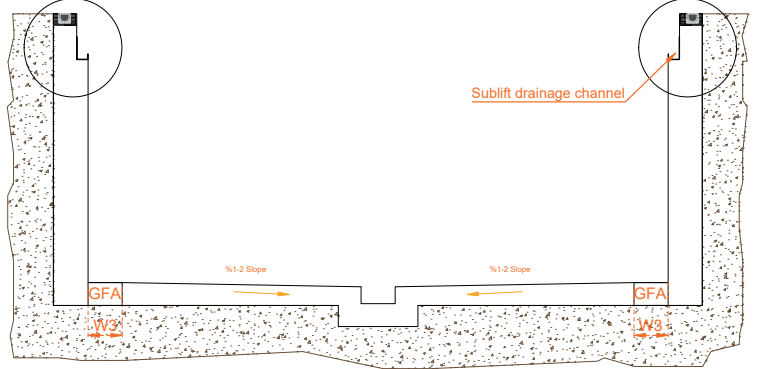

Front Pit View

DETAIL E

DETAIL A

DETAIL B

DETAIL C

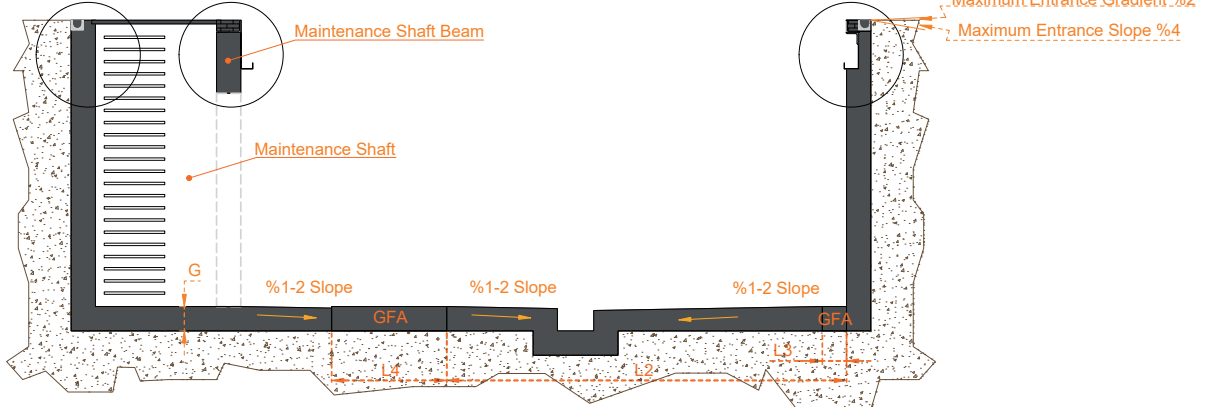

Side View

11 SUBLIFT H1W1-W2

- ▣ Gradient free area (GFA) (L3, L4 and W3) indicates a space where shall be no gradient or slope. Construction the pit in accordance with slope directions and gradient free area is performed by the customer.
- ▣ Pit construction details (Detail A, Detail B, Detail C, Detail D, Detail E) are different from each other. Please check proper detail sections above before designing the pit. To have further information, please see "Sublift Drainage Details", page 11.
- ▣ Hydraulic unit is placed in the maintenance shaft. The access to pit, shaft ladder and shaft cover have to be performed by the customer. The safety precautions to the access pit have to be conducted by the customer.
- ▣ Door between the maintenance shaft and the Sublift's pit to be installed by the customer.
- ▣ Surrounding drainage system and sewerage system are executed by the customer.
- ▣ Dimensions for the drainage channel with grating in the pit are 10 x 2 cm with sump 50 x 50 x 50 cm. The drainage channel must be connected to the sewerage system or the water must be drained away by a pump provided by the customer. For sump pump's dimensions please consult its manufacturer.
- ▣ SSL (Structural Slab Level) describes the floor level prior to the addition of surface finishing items such as screed, underlay and flooring. FFL (Finish floor level) refers to the uppermost surface of a floor once construction has been completed with tiles, marble, stone, or different means. Surface finishing is to be provided by the customer.
- ▣ It is possible to apply the surface finishing on top of Sublift's roof. In such case, please consult Sanpark.
- ▣ Any waterproofing work shall be carried by the customer.
- ▣ Maintenance shaft beam must be minimum 50 cm.
- ▣ Maximum entrance gradient (%2) and slope (%4) details are specified in the illustrations of the sideview at page 10. Improper layout causes extreme difficulties and Sanpark does not accept any responsibilities.

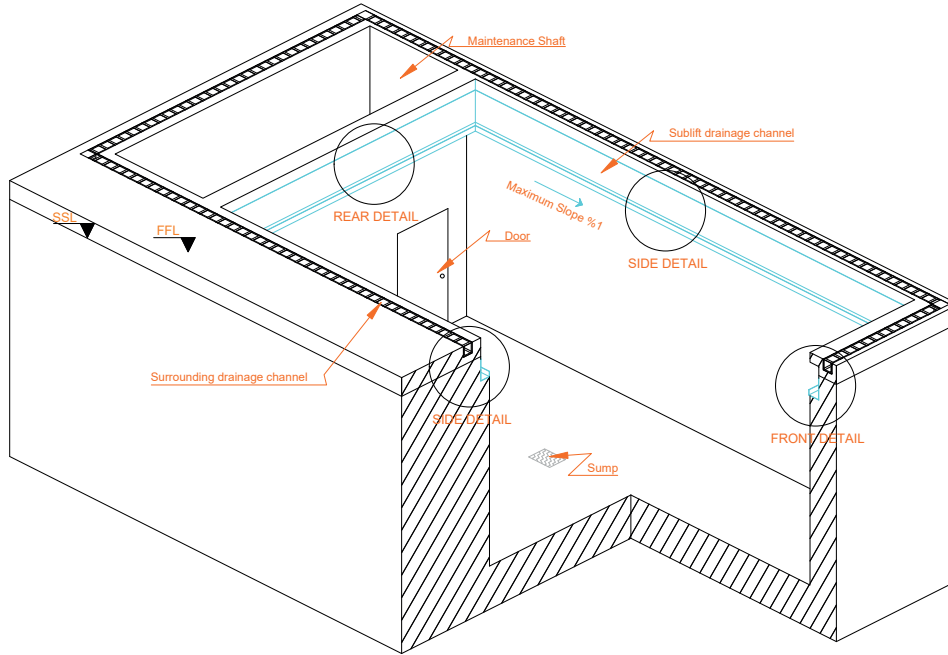

SUBLIFT DRAINAGE DETAILS

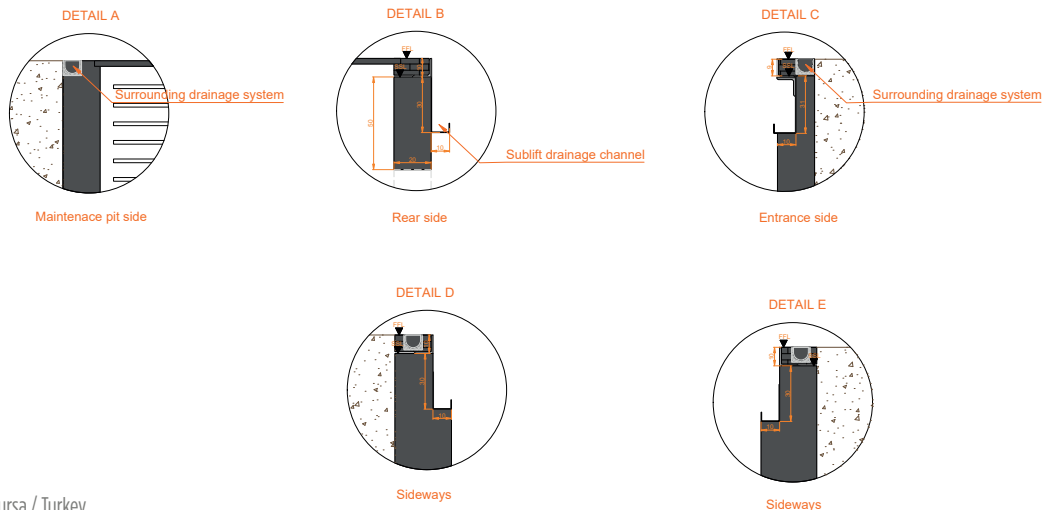

TECHNICAL INFORMATION**Installation**

Sublift requires crane and forklift for installation. It is under customer's responsibility to provide these vehicles.

The heaviest part is 300 kg so please consult local companies to hire proper crane and forklift. Please request a consultation for more detail about Sublift.

**Hydraulic Unit**

Up to 3 Sublift can be grouped as one so they can share the common hydraulic unit to reduce the overall price. In such a case, each group of systems cannot be operated separately. A separate power unit is recommended to reduce dependency. Please request a consultation for planning the project.

**Temperature**

Majortrio is designed to operate between -15° and +40°C at atmospheric humidity of 50 percent. If the local temperature is different from the above, please consult Sanpark.

**Conformity Test**

All our systems comply with EC machinery directive 2006/42/EC and TS/EN 14010:2009 +A1:2009.

**Building application documents**

All our systems generally require local approval. Please observe local regulations.

**Maintenance**

Regular maintenance by qualified personnel can be provided by an Annual Service Contract.

**Care and Corrosion Protection**

Due to the corrosion danger, apart from regular maintenance, all our galvanized equipment and platforms must be regularly cleaned up salt water, dirt, leak, any chemical substance, and sand. The garage and pits must be always ventilated well.

**Railings**

If passageways are directly next to the systems, railings have to be provided according to TS EN ISO 13857 by the client according to local requirements, height min. 200 cm.

**Fire Safety**

All fire safety requirement(s) and all possible mandatory item(s) and equipment(s) must comply with local regulations and must be provided by the customer.

**Noise Protection**

In compliance with DIN 4109-1 Noise protection: Maximum sound pressure level in living and sleeping areas 30 dB (A).

User noise like accessing the platform, the slamming of vehicle doors, the vehicle's engine, and brake noise are not subject to the requirements.

In order to provide 30 dB (A) in rooms the following conditions are required;

Additional Sanpark noise protection package according to quote.

Insulation figure of the construction of min R'w= 57 dB (in the customer's responsibility)

Walls that are close to the parking systems must be done as a single wall and deflection resistant with min. m'= 300 kg/m2 (in the customer's responsibility)

The solid ceiling above the parking systems with min. m'= 400 kg/m2 (in the customer's responsibility)

At differing constructional conditions, additional sound-absorbing methods are in the customer's responsibility.

COMPONENTS**SUBLIFT COMPONENTS**

2 Steel columns with base plates.
 2 Mechanical Locking devices
 2 Platforms
 1 Hydraulic cylinder
 Anchors, screws, connectors, bolts, etc.
 1 Mechanical synchronization system.

Platform Components

Platform profiles
 Side beams
 Adjustable positioning aid
 Platform base sections
 Chamfered ramp
 Screws, nuts, washers, spacers, etc.

Electrical System Components

Emergency stop
 Electrohydraulic lock
 Electro mechanic lock
 Distributor board
 Junction box
 1 Master key for each Majortrio.

Hydraulic System Components

Hydraulic cylinders
 Solenoid valve
 Safety valve
 Screwed joints
 High-pressure hoses
 Attachments

Hydraulic Unit Component

Hydraulic power unit
 Hydraulic oil reservoir
 Oil filling
 Internal gear Pump
 Pump holder
 Coupling
 3 phase AC motor (5.5 kW, 380 V, 50 Hz)
 Contactor
 Pressure relief valve
 Hydraulic hoses

Sanpark's engineering department is constantly challenging itself to improve its systems. In the event of technological advancement, Sanpark can adopt newer or different technologies, systems, or standards to improve overall quality.

SERVICES TO BE PROVIDED BY THE CUSTOMER**Warning Marking**

According to DIN EN 14010, the floor has to be marked with 10 cm wide yellow-black stripes to indicate the operation area by the purchaser to point out the dangerous area.

**Supply Cable to Master Switch**

The customer must run the supply cable to the master switch during assembly.

**Barriers**

In accordance with DIN EN 13857, barriers may be required in case of passageways in front of, behind, or next to the systems.

**Earth Foundation**

The customer must earth the steel structure with a foundation earth connection and lay equipotential bonding according to local regulations.

**Parking Space Numbering**

Numbering the parking spaces.

**Drainage**

For environmental protection, we advise applying coating the pit floor. Oil and/or fuel separators should be installed in accordance with local regulations. To drain large quantities of water from the yard, the customer must install a water collection channel around the system.

**Lighting**

It is in the customer's responsibility to check local regulations regarding the illumination of parking spaces.

**Conduits and Wall Openings**

Any conduit and wall opening work belongs to the customer, yet Sanpark can assist during the planning phase in such cases. Please consult Sanpark if necessary.

CERTIFICATES

ZERTIFIKAT | CERTIFICATE | CERTIFICAT | CERTIFICADO | CERTIFICAT | 証明書 | 證書 | 인증서



EG-BAUMUSTERPRÜFBESCHEINIGUNG

TUV AUSTRIA TÜRK ist benannte Stelle
nach der Maschinenrichtlinie 2006/42/EG unter der Nummer 2737

Bescheinigung Nr.: 21-MD-TEC-063-TAT-2021-033

Antragsteller : SANMAK MAKİNE SANAYİ VE TİC. A.Ş.
Çalı Sanayi Bölgesi Çalı Mh 6. Sk. N:8 Nilüfer / Bursa

Hersteller : SANMAK MAKİNE SANAYİ VE TİC. A.Ş.
Çalı Sanayi Bölgesi Çalı Mh 6. Sk. N:8 Nilüfer / Bursa

Design des Produkts : Mehrschichtiger, elektrohydraulischer mechanischer Parklift

Typ/Modell : # IDEALIFT H2W1, IDEALIFT H2W2, IDEALIFT H3W1, IDEALIFT H3W2 #
IDEALOW H2W1, IDEALOW H2W2, IDEALOW H3W1, IDEALOW H3W2 #
MAJORLIFT, MAJORTRIO, OPTILIFT, ROBUST-SLIMO #
SUBLIFT H1W1, SUBLIFT H1W1, SUBLIFT H1W2, SUBLIFT H2W1,
SUBLIFT H2W2, SUBLIFT H3W1, SUBLIFT H3W2

Warenzeichen / Marke : SANPARK

**Norm(en)/
Angewandte Regelwerke:** : 2006/42/EG Maschinenrichtlinie
EN ISO 12100:2010
EN 14010:2003+A1:2009

Diese Konformitätsbewertung wird auf Kundenwunsch gemäß Maschinenrichtlinie 2006/42/EG Artikel 12 3.b
ausgestellt. Die in Anhang IV aufgeführten Geräte entsprechen der harmonisierten Norm und Anhang I den
grundlegenden Gesundheits- und Sicherheitsanforderungen der Richtlinie. Sie bezieht sich nur auf das jeweilige
Muster und dessen technische Unterlagen, die zur Einschichtnahme vorgelegt werden.

Technische Datei Nr : 21-MD-TEC-063/TF-01
MIT* Dokument Nr : MD-2737-2100004
Assessor-ID-Nr. : TU-MD-001
Datum/Ort der Begutachtung : 01.10.2021
Ausstellungsdatum : 09.11.2021
Ablaufdatum : 08.11.2026

CE 2737 Nach Erstellung der notwendigen technischen Dokumentation sowie der
Konformitätserklärung kann die erforderliche CE-Kennzeichnung auf dem Produkt
angebracht werden. Weitere relevante Richtlinien sind zu berücksichtigen.

Diese Konformitätserklärung wurde dem Antragsteller auf Grundlage der Ergebnisse der Prüfungen durch
den Antragsteller / Hersteller oder einem anerkannten Labor und der im Prüfbericht angeführten
Konformitätsbewertung des TÜV AUSTRIA TÜRK ausgestellt. Änderungen der angewandten
Regelwerke/Normen sowie der Materialien, der Komponenten, der Fertigung oder der Gestaltung können eine
teilweise oder gänzliche Wiederholung der Prüfungen erforderlich machen, um die Gültigkeit der
Bescheinigung aufrecht zu erhalten. report and therefore this associated certificate to remain valid.

TÜV AUSTRIA TÜRK
Genehmigt von
Ali Osman ÖZVEREN

CE 2737

Ministerium für Industrie und Technologie

**CERT-MD-001 EG-
BAUMUSTERPRÜFBESCH
EINZUG**
Revision: 02 Datum: 09.03.2020
Seite: 1/1

TÜV AUSTRIA TÜRK
Ausgewiesene Vervielfältigung nur mit Genehmigung des TÜV AUSTRIA TÜRK.
Alle Prüf- und Überwachungsleistungen wurden nach dem QM-System des TÜV
AUSTRIA TÜRK durchgeführt.

**Cemra Mah. İsmail Çelebi
Dış. Sk. No:28 PK:34774
Ünversite / ETAMÜSÜL
E-Mail: info@tuvtrk.com.tr**

QR Code



CERTIFICATE

Sanmak
Makina Sanayi ve Ticaret A.Ş.

ŞANMAK MAKİNA SAN. VE TİC. A.Ş.

ÇALI SANAYİ BÖLGESİ 6. SOK. NO:8
NİLÜFER / BURSA / TÜRKİYE

*Has been assessed and found to Comply with the Requirements of:
Denetlenmiş ve aşağıdaki standardın gerekliliklerine uygunluğu görülmüştür:*

ISO 9001:2015

*The Quality Management System is applicable to:
Kalite Yönetim Sistemi:*

**DESIGN, PRODUCTION AND SERVICE SERVICES OF MACHINES
FOR VEHICLE, LOAD LIFTING AND TRANSPORT**

**TAŞIT, YÜK KALDIRMA VE TAŞIMA AMAÇLI MAKİNALARIN
TASARIMI, ÜRETİMİ VE SERVİS HİZMETLERİ**

Certificate Number: QMS-05807
Belge Numarası: QMS-05807

Initial Certification Date: 15.12.2021
İlk Belgelendirme Tarihi: 15.12.2021

Certificate Validity Date: 14.12.2022
Belge Geçerlilik Tarihi: 14.12.2022

Certification Period: 3 Years
Belgelendirme Periyodu: 3 Yıl

**INTERNATIONAL
CERTIFICATION FORUM**

IAS
ACCREDITED
Management Systems
Certification Body
MSCB-135

IQR

IQR Sertifikasyon Onayı

IQR ULUSLARARASI BELGELENDİRME HİZMETLERİ LTD.ŞTİ.
Beşevler Mah. Kocayunus Sk. No:3 Anadolı Han Plaza K:2 Nilüfer / BURSA
Tel: +90 224 226 00 16 Faks: +90 224 249 41 13 www.iqrcert.com e-posta: info@iqrcert.com

1 **SUBLIFT H2W1-W2**

SUBLIFT H2W1-W2

Mechanical parking system for outdoor usage with require a pit.

DATA SHEET



WE
EXPAND
YOUR PARKING
CAPACITY

2 **SUBLIFT H2W1-W2****TABLE OF CONTENTS**

TABLE OF CONTENTS	2
GENERAL DESCRIPTION	2
LENGTH DETAILS	3
VEHICLE DETAILS, CLEARANCE & DIMENSIONS	4
HEIGHT DETAILS	5
WIDTH DETAILS	6
ELECTRICITY INSTALLATION DIAGRAM	8
LOADS AND CONSTRUCTION DETAILS	9
PIT CONSTRUCTION DETAILS	10
TECHNICAL INFORMATION	13
SUBLIFT COMPONENTS	14
SERVICES TO BE PROVIDED BY THE CUSTOMER	14
CERTIFICATES	15

GENERAL DESCRIPTION

- ▣ Sublift is an independent parking system for an indoor or outdoor application and it allows 2, 3, 4 vehicles to be parked on top of each other in respect to its types in a parking space that merely allows 1 vehicle under normal condition.
- ▣ The vehicle capacity of the Sublift H2W1 system is 2 and Sublift H2W2 is 4.
- ▣ Sublift platforms moves vertically.
- ▣ The height, width and length of the platform can be customized according to the customer's request. (see "Height and Width Details", page 5-6).
- ▣ The lifting capacity of the platforms can be customized according to the customer's request. (see "Loads and Construction Details", page 9).
- ▣ The operating key is installed in front of the columns or on the outside.
- ▣ Hot-dip galvanization is applied to the main construction.
- ▣ It is safe and secured with an automatic electromagnetic mechanic position locker.
- ▣ All dimensions are minimum and tolerance for dimensions +3/-0 cm.

LENGTH DETAILS

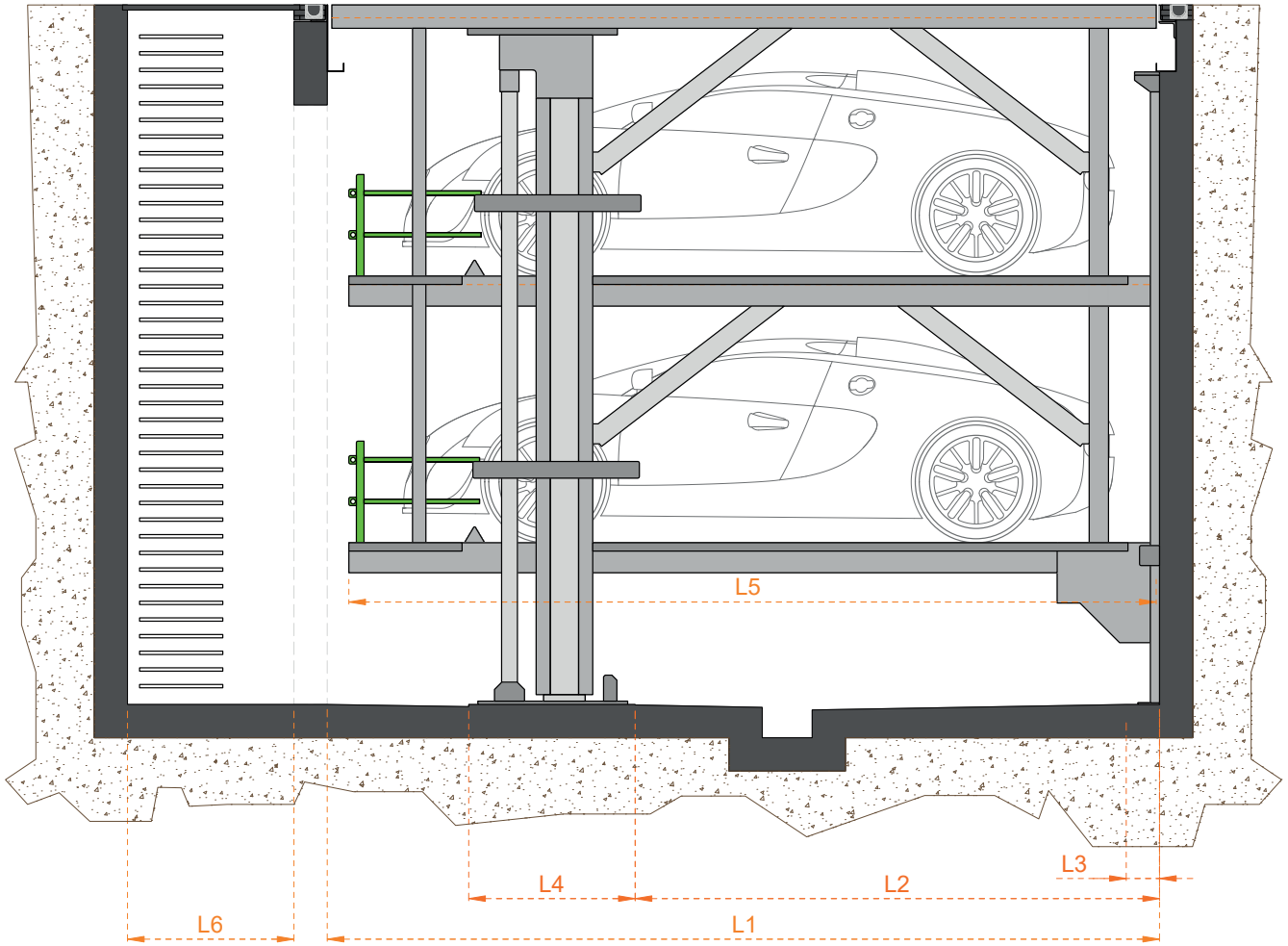

All dimensions are given in cm.

- Maximum vehicle length dimensions can be like the following table. In case of shorter and longer versions, please consult Sanpark.

Operation

With the help of "Hold-to-Run" device which automatically returns to the "off" position after release. Sublift's users securely operate the system.

SUBLIFT LENGTH DIMENSIONS

Maximum Vehicle Length	Platform Length (L5)	Required Space (L1)	Column Position (L2)	Gradient Free Space (L3)	Gradient Free Space (L4)
475 cm	485 cm	500 cm	330 cm	20 cm	95 cm
500 cm	510 cm	525 cm	360 cm	20 cm	95 cm
520 cm	530 cm	550 cm	380 cm	20 cm	95 cm

- Gradient free space (L3 and L4) indicates a space where shall be no gradient or slope.
- The position of the (L4) is determined by the position of the column (L2).
- Length of maintenance pit (L6) is 100 cm.

Independent Parking

All parking spaces and vehicles in the system can be used without blocking one another.

VEHICLE DETAILS, CLEARANCE & DIMENSIONS

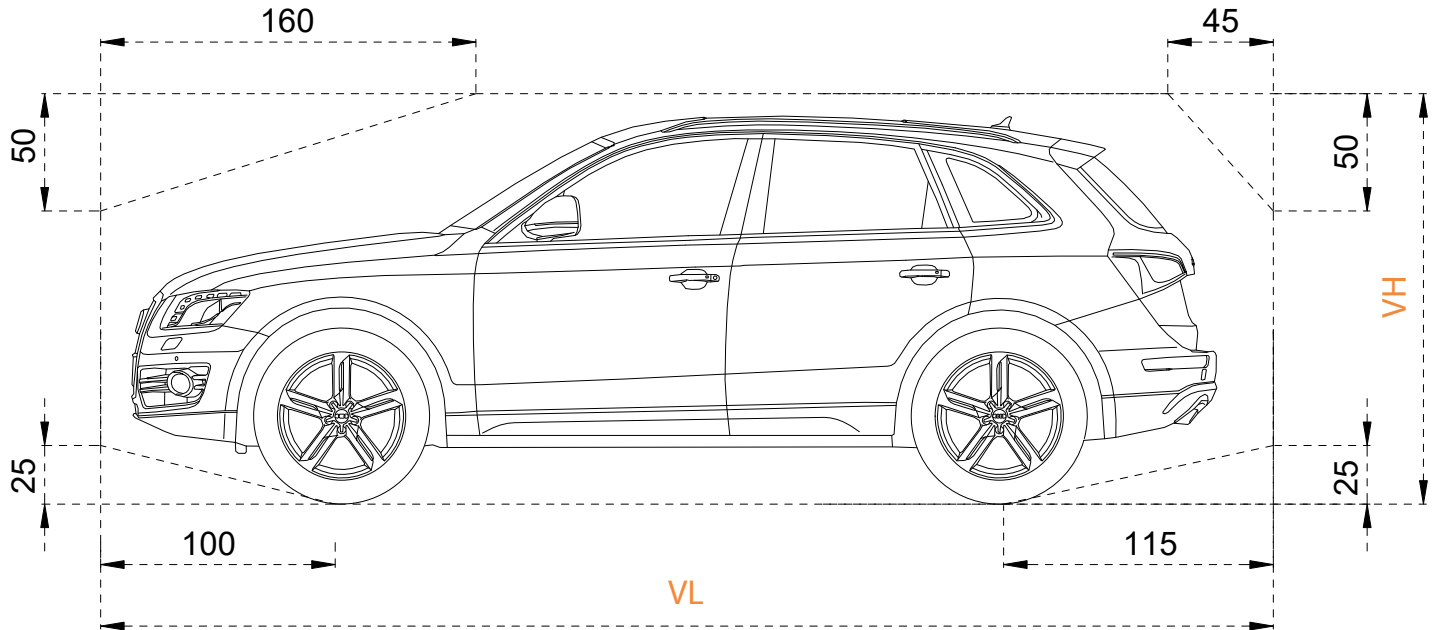

Vehicle Length (VL)	see "Length Details", page 3
Vehicle Height (VH)	see "Height Details", page 5
Vehicle Width	see "Width Details", page 6
Vehicle Weight	see "Loads and Construction Details", page 9
Wheel Load	500 KG
Vehicle Types	Saloon, Estate, SUV, Van

The overall vehicle height including roof luggage rails and antenna mounts must not exceed the max. vehicle height dimensions specified

▣ The following car heights shared as a guide to help you to select the platform distance and construction dimensions;

Volkswagen Golf	149 cm
Volkswagen Tiguan	167 cm
Volkswagen T-Roc	160 cm
Volkswagen T-Cross	159 cm
Volkswagen Passat	152 cm
Dacia Sandero	150 cm
Dacia Duster	170 cm
Renault Clio	145 cm
Renault Captur	158 cm
Fiat/Abarth 500	150 cm
Fiat Panda	156 cm

Tesla Model 3	145 cm
Tesla Model X	169 cm
Ford Kuga	169 cm
Ford Puma	156 cm
Mercedes A-Class	146 cm
Mercedes G-Class	198 cm
Mini Hatch	145 cm
Hyundai Kona	156 cm
Opel/Vauxhall Corsa	149 cm
Volvo XC40	166 cm
Skoda Octavia	147 cm
Hyundai Tucson	167 cm

Peugeot 208	146 cm
Peugeot 2008	155 cm
Peugeot 3008	163 cm
Toyota Corolla	144 cm
Toyota Yaris	151 cm
Toyota RAV4	169 cm
Toyota Camry	145 cm
Citroen C3	161 cm
Porsche Macan	163 cm
Porsche Cayenne	168 cm
BMW 3-Series	143 cm
BMW iX	170 cm
BMW X5	175 cm
Volvo XC 90	178 cm
Land Rover Discovery	189 cm
Land Rover Range Sport	180 cm

All vehicle heights may vary due to the wide range of models and manufacturing year.

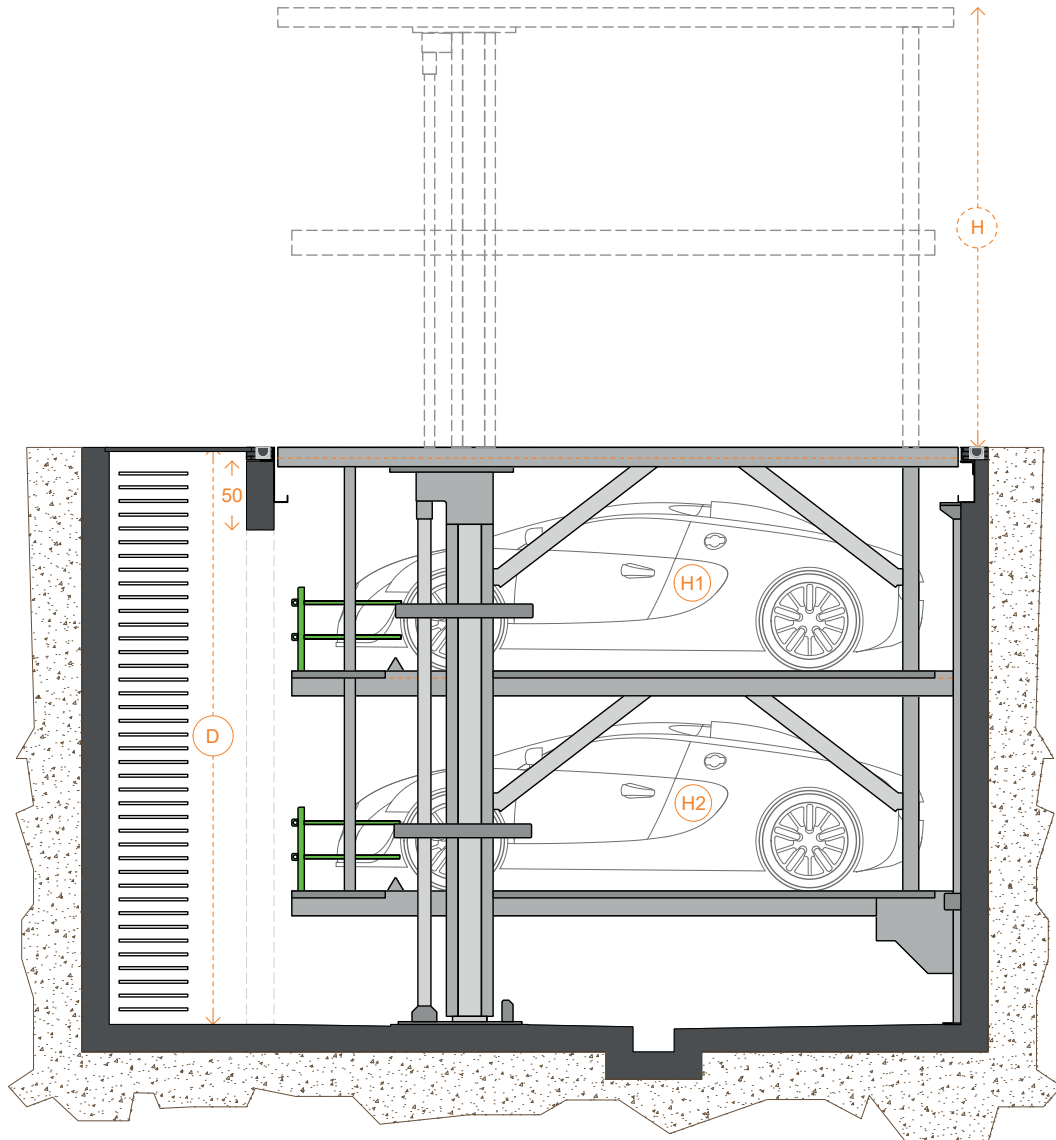
HEIGHT DETAILS

- ▣ The table below indicates vehicle heights (**H1**) and their corresponding operation height (**H**) and their relevant pit depth (**D**). Various versions are available upon request so please contact to have technical support if it is necessary.
- ▣ It is recommended that Vehicle Height (**H1**) should be higher than an average human height for drivers to conveniently get out of the vehicle.
- ▣ Maintenance shaft beam is supposed to be minimum 50 cm.

SUBLIFT H2W1 HEIGHT DIMENSIONS

Car Height (H1)	150	155	160	165	170	175	180	185	190	195	200	205
Height (H)	320	330	340	350	360	370	380	390	400	410	420	430
Pit Depth (D)	420	430	440	450	460	470	480	490	500	510	520	530

SUBLIFT H2W2 HEIGHT DIMENSIONS

Car Height (H1)	150	155	160	165	170	175	180	185	190	195	200	205
Height (H)	320	330	340	350	360	370	380	390	400	410	420	430
Pit Depth (D)	440	450	460	470	480	490	500	510	520	530	540	550

All dimensions are given in cm.

WIDTH DETAILS

For Sublift H2W1

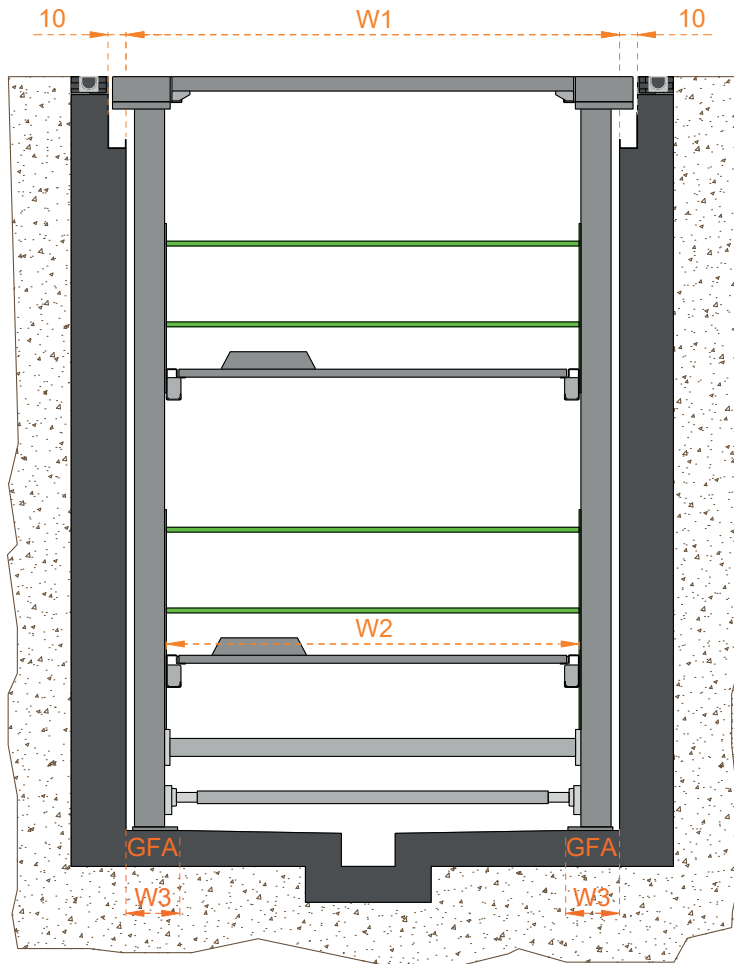
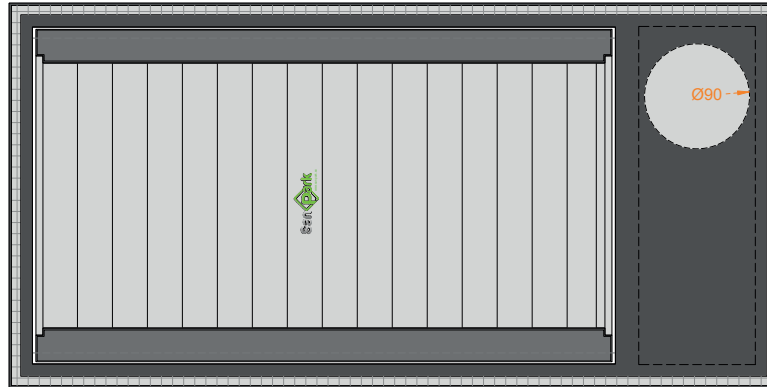

▣ The following figures demonstrate the required width for parking areas and their correspondence to clear platform width.

SUBLIFT MONO WIDTH

Pit Width (W1)	260 cm	270 cm	280 cm	290 cm
Platform Width (W2)	220 cm	230 cm	240 cm	250 cm
Gradient Free Space Width (W3)	30 cm	30 cm	30 cm	30 cm

Reducing parking width lowers parking comfort according to the vehicle width, vehicle type, and individual driving style.

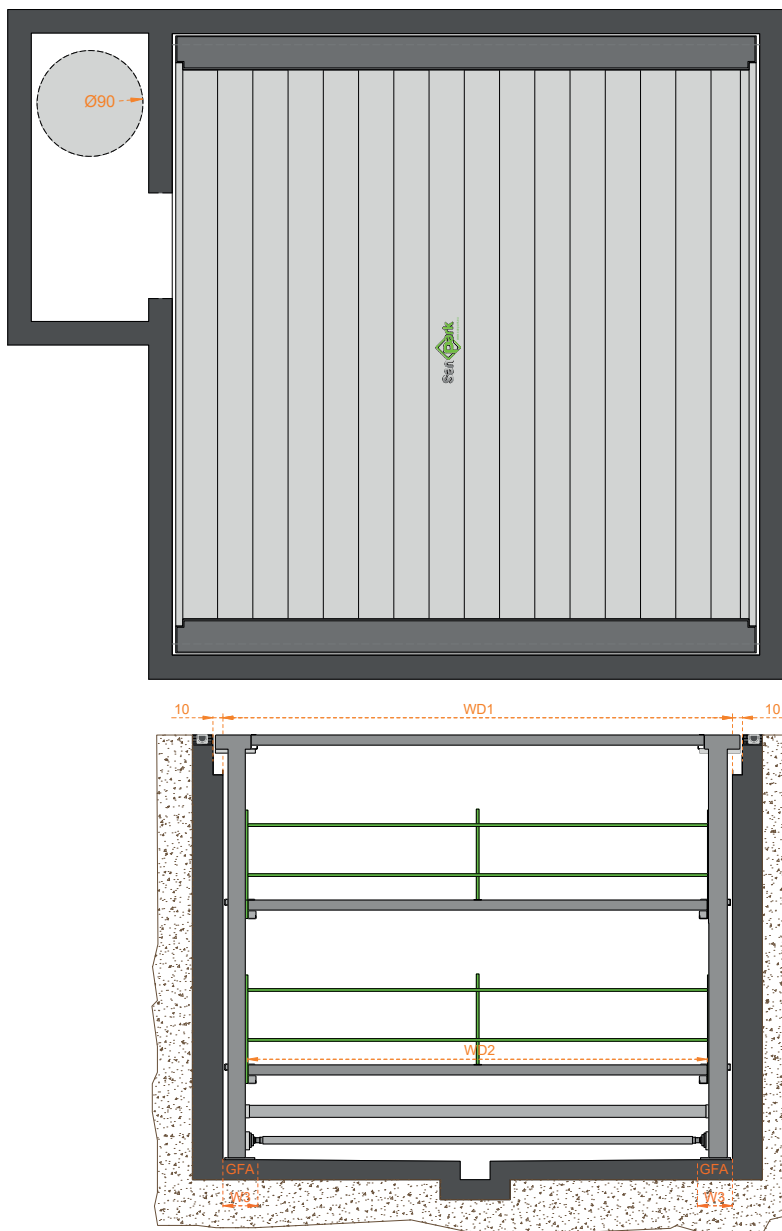
WIDTH DETAILS**For Sublift H2W2**

- The following figures demonstrate the required width for parking areas and their correspondence to clear platform width.

SUBLIFT DOUBLE PLATFORM WIDTH

Pit Width (WD1)	500 cm	510 cm	520 cm	530 cm
Platform Width (WD2)	450 cm	460 cm	470 cm	480 cm
Gradient Free Space Width (W3)	30 cm	30 cm	30 cm	30 cm

Reducing parking width lowers parking comfort according to the vehicle width, vehicle type, and individual driving style.

- Ground level pit width is different from the width inside the pit due to drainage channels. Please see "Pit Construction Details", page 9 for more detail.
- We recommend 250 centimeters platform width for convenient parking.
- While setting driving lane width, please check local regulations.
- There must be no gradient or slope at Gradient Free Space Width (**W3**) to install the machine properly.
- The roof also can support one car but the system cannot be operated with it for a standard machine. It is possible to operate the machine with the vehicle on the roof with a special design and please consult Sanpark in such cases.

ELECTRICITY INSTALLATION DIAGRAM

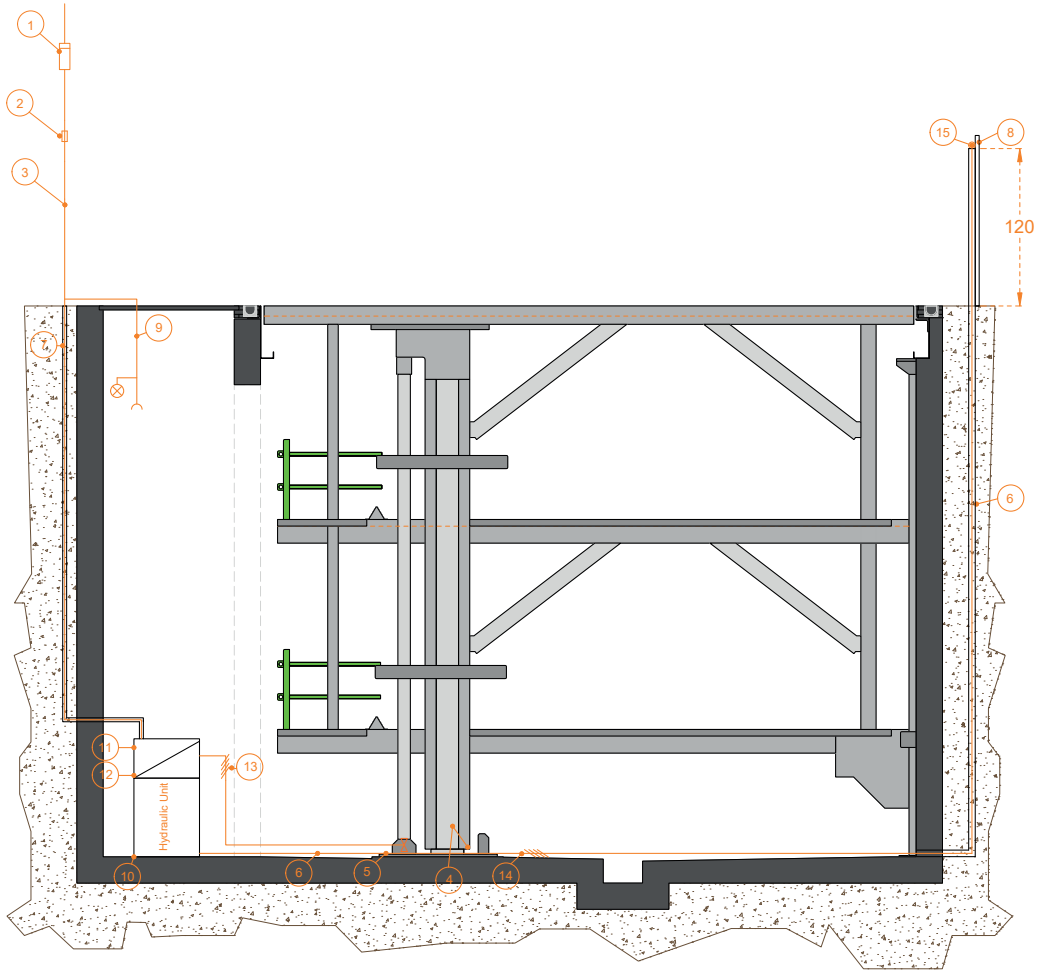

- During installation, it is required to appropriately connect electrical components with the wiring diagram supplied by the manufacturer in accordance with local regulations.

ELECTRICAL DETAILS (In the customer responsibility)

NUMBER	QUANTITY	DEFINITION	POSITION	FREQUENCY
1	1	Electricity meter	in the supply cable	
2	1	3x Safety fuse 40 & Circuit breaker 3x 40 A (Trip Characteristic C)	in the supply cable	1 x per unit
3	1	Supply cable 5x4 mm ² (3 PH+PE) or PLC type (3 PH+N+PE) with marked wires and protective earth	supply cables to the main switch	1 x per unit
4	Every 10 m	Foundation earth connection	corner or middle of pit floor	
5	1	Equipotential bonding in accordance with DIN EN 60204 from foundation earth connection to system		1 x per system
6	1	Empty pipe EN 40 (M40) with taut wire	from pit floor to operating device	1 x per system
7	1	Empty pipe EN 50 (M50) with taut wire	supply cable to hydraulic unit	1 x per unit
8	1	Operation device base		1 x per system
9	1	Separate supply cable 230 V with lighting and socket	from the electricity meter in the maintenance shaft	1 x per system

ELECTRICAL DETAILS (In Sanpark responsibility)

NUMBER	DEFINITION
10	Hydraulic unit 7.5 kW, three-phase current 230/400 V 50 Hz
11	Switch cabinet with lockable master switch
12	Control cable 4x4 mm ² with marked wires and protective earth
13	Control cable 2x0.75 mm ² with marked wires and protective earth
14	Control cable 7x1 mm ² with marked wires and protective earth
15	Operating device

LOADS AND CONSTRUCTION DETAILS

For Sublift H2W1

■ The systems are anchored into the ground. The drill hole depth in the floor plate is approx. 14 cm, in the walls approx. 10 cm. If the precise figures are required, please consult Sanpark.

■ Concrete quality according to the static requirements of the building. However, we require a slab thickness (G) minimum of 20 cm and a concrete quality of min. C20/25 to anchor the system.

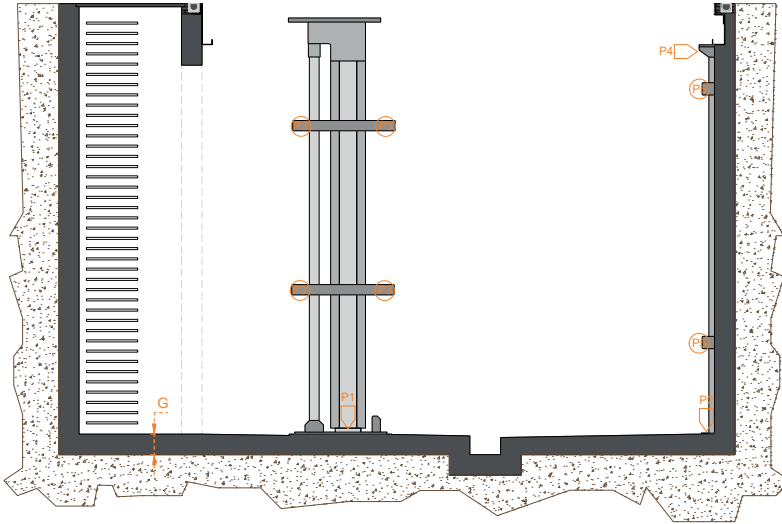

		MONO PLATFORM STRUCTURAL FORCES (kN)				
		P1	P2	P3	P4	P5
CAR WEIGHT	2000 KG	± 70	± 13	± 22	± 35	± 14
	2600 KG	± 82	± 14	± 26	± 41	± 16
	3000 KG	± 95	± 16	± 29	± 43	± 17

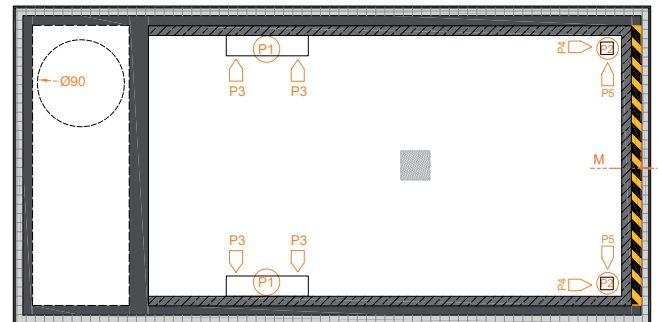

For Sublift H2W2

■ The systems are anchored into the ground. The drill hole depth in the floor plate is approx. 15 cm, in the walls approx. 12 cm. If the precise figures are required, please consult Sanpark.

■ Concrete quality according to the static requirements of the building. However, we require a slab thickness (G) minimum of 20 cm and a concrete quality of min. C25/30 to anchor the system.

■ Standard lifting capacity is 2000 kg but it is also possible to increase the capacity to 2600 kg and 3000 kg. In case of further capacity, please consult Sanpark.

■ According to DIN EN 14010, the floor has to be marked with 10 cm wide yellow-black stripes (M) to point out the dangerous area. The marking must comply with ISO 3864.

		DOUBLE PLATFORM STRUCTURAL FORCES (kN)				
		P1	P2	P3	P4	P5
CAR WEIGHT	2000 KG	± 90	± 24	± 41	± 67	± 27
	2600 KG	± 99	± 29	± 49	± 80	± 29
	3000 KG	± 116	± 29	± 53	± 64	± 32

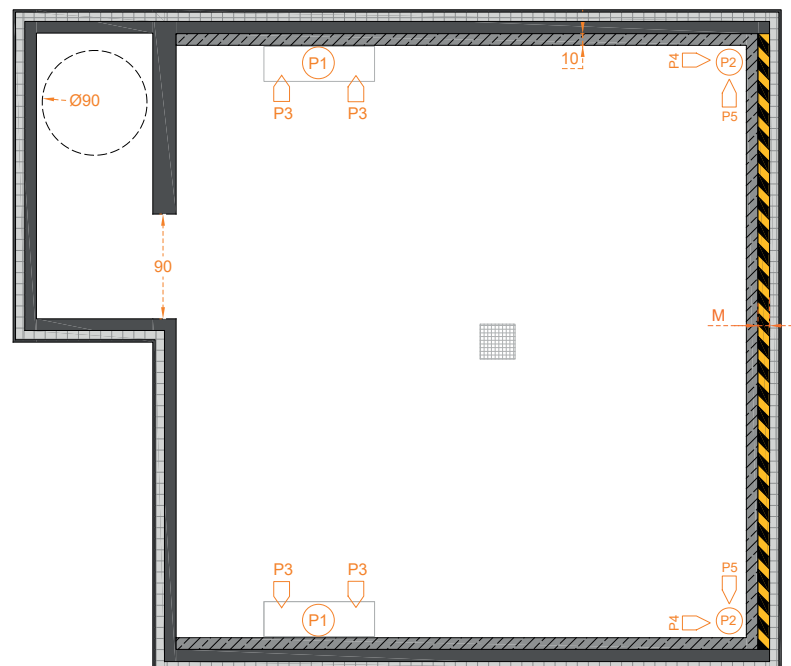

PIT CONSTRUCTION DETAILS

For Sublift H2W1

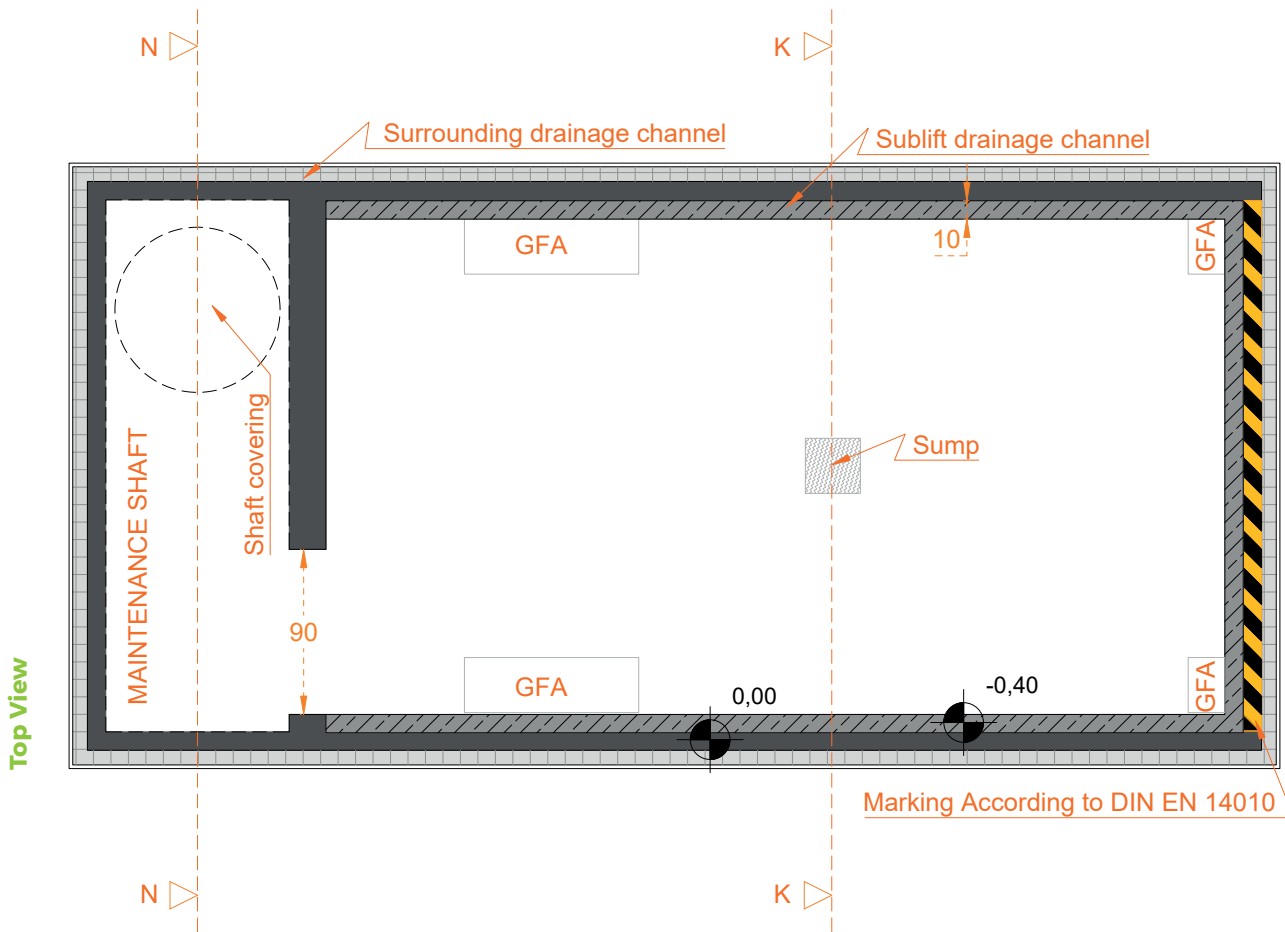

N-N DETAIL

Front Maintenance Shaft

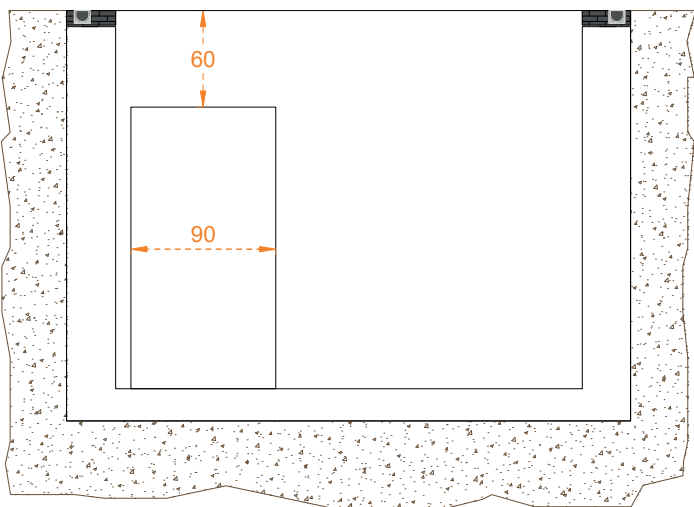

K-K DETAIL

DETAIL D

DETAIL E

Front Pit View

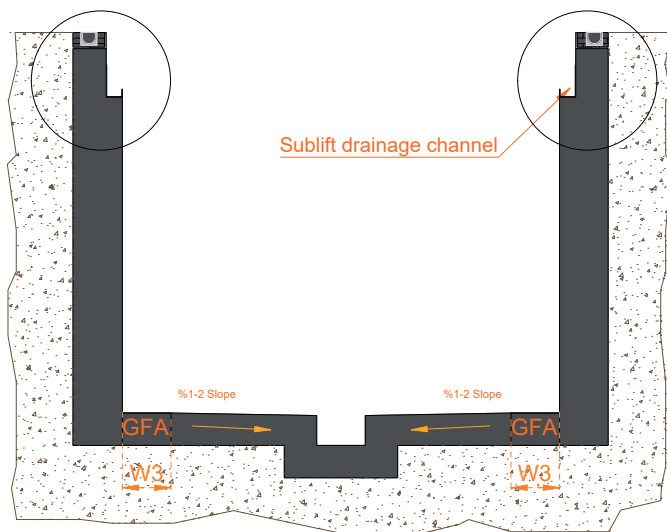

11 SUBLIFT H2W1-W2

For Sublift H2W2

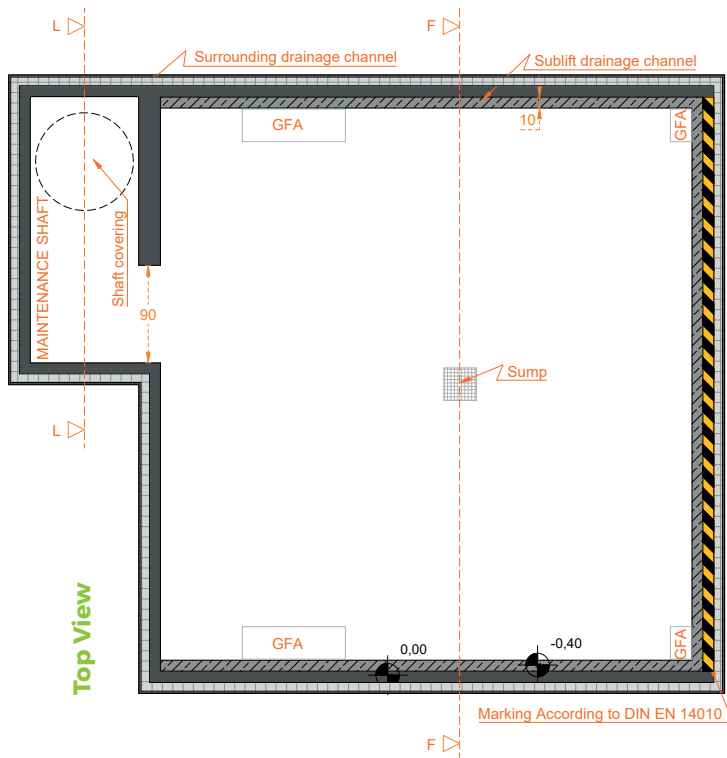

Top View

L-L DETAIL

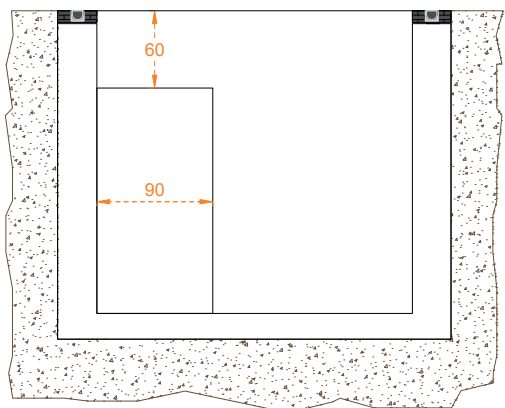

Front Maintenance Shaft

F-F DETAIL

DETAIL D

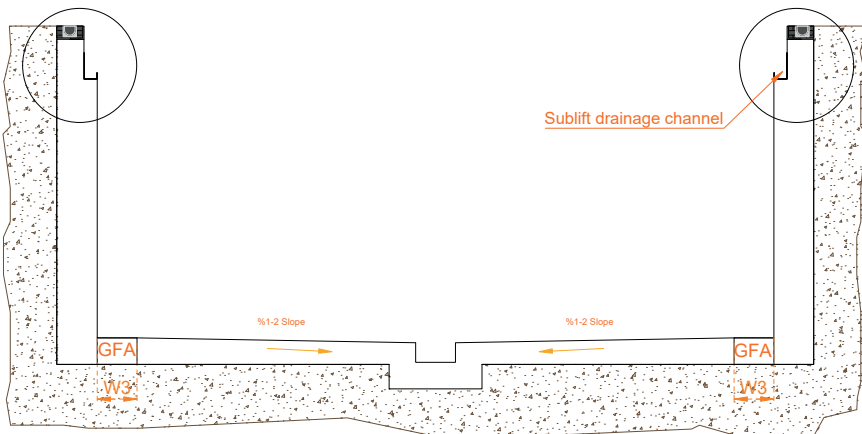

Front Pit View

DETAIL E

DETAIL A

DETAIL B

DETAIL C

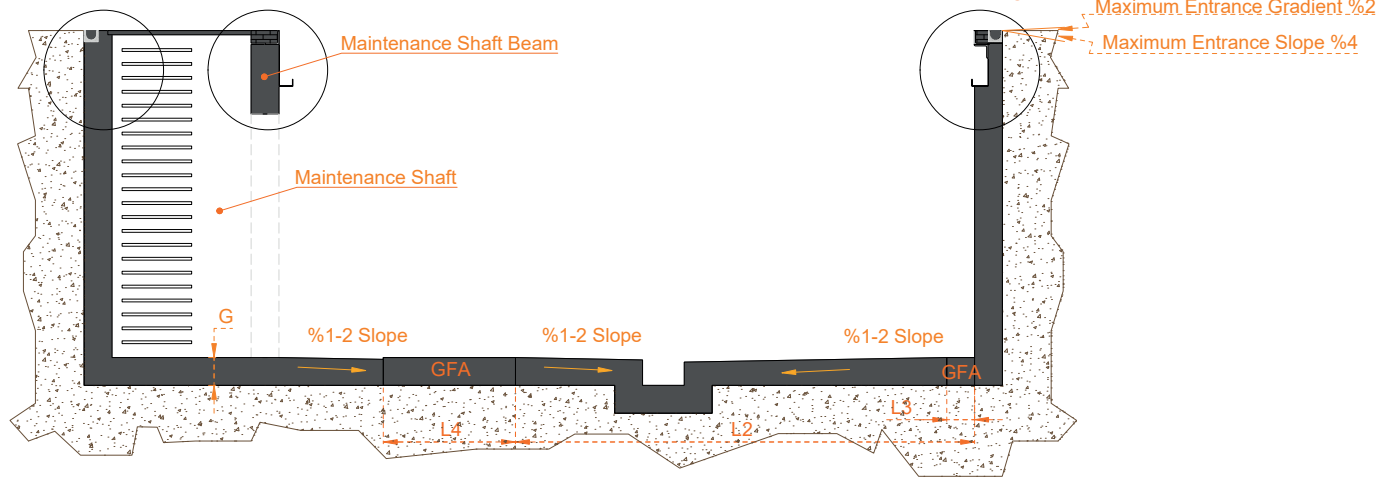

Side View

12 SUBLIFT H2W1-W2

- ▣ Gradient free area (GFA) (L3, L4 and W3) indicates a space where shall be no gradient or slope. Construction of the pit in accordance with slope directions and gradient free area is performed by the customer.
- ▣ Pit construction details (Detail A, Detail B, Detail C, Detail D, Detail E) are different from each other. Please check proper detail sections above before designing the pit. To have further information, please see "Sublift Drainage Details", page 12.
- ▣ Hydraulic unit is placed in the maintenance shaft. The access to pit, shaft ladder and shaft cover have to be performed by the customer. The safety precautions to the access pit have to be conducted by the customer.
- ▣ Door between the maintenance shaft and the Sublift's pit to be installed by the customer.
- ▣ Surrounding drainage system and sewerage system are executed by the customer.
- ▣ Dimensions for the drainage channel with grating in the pit are 10 x 2 cm with sump 50 x 50 x 50 cm. The drainage channel must be connected to the sewerage system or the water must be drained away by a pump provided by the customer. For sump pump's dimensions please consult its manufacturer.
- ▣ SSL (Structural Slab Level) describes the floor level prior to the addition of surface finishing items such as screed, underlay and flooring. FFL (Finish floor level) refers to the uppermost surface of a floor once construction has been completed with tiles, marble, stone, or different means. Surface finishing is to be provided by the customer.
- ▣ It is possible to apply the surface finishing on top of Sublift's roof. In such case, please consult Sanpark.
- ▣ Any waterproofing work shall be carried by the customer. Maintenance shaft beam must be minimum 50 cm.
- ▣ Maximum entrance gradient (%2) and slope (%4) details are specified in the illustrations of the sideview at page 10. Improper layout causes extreme difficulties and Sanpark does not accept any responsibilities.

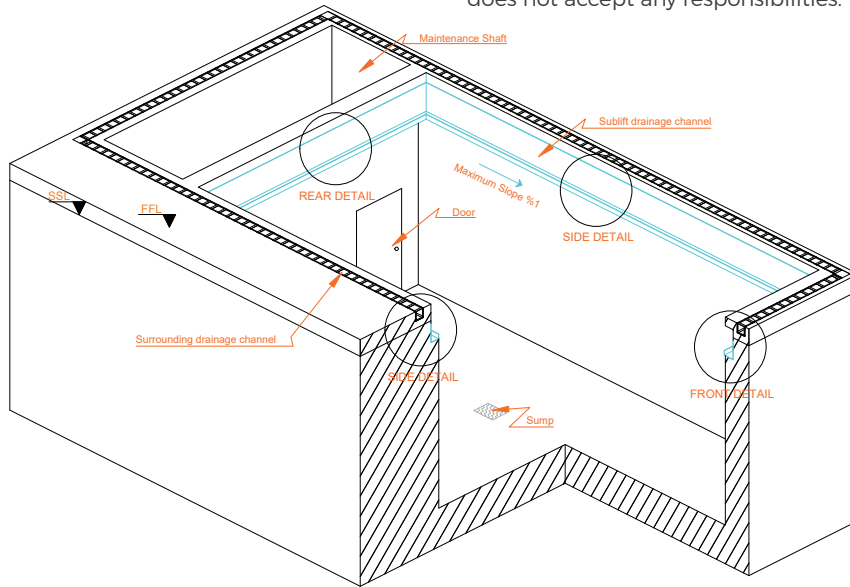

SUBLIFT DRAINAGE DETAILS

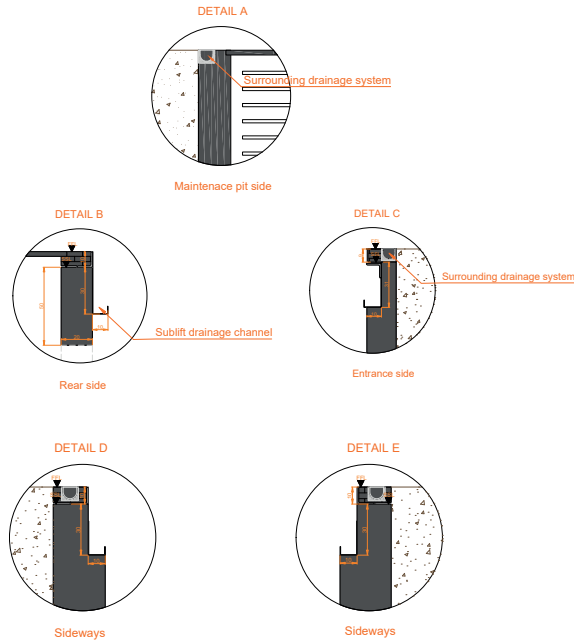

TECHNICAL INFORMATION**Usage Area**

In order to park in or out of the vehicle at the upper level, the vehicle on the ground floor must be parked out first, which is why this system is advised to be used by permanent users. In case of short-time users (e.g. hotel, office, commercial building) we recommend the appointment of a valet for operation conveniently. Please request a consultation if required.

**Hydraulic Unit**

Up to Sublift can be grouped as one so they can share the common hydraulic unit to reduce the overall price. In such a case, each group of systems cannot be operated separately. A separate power unit is recommended to reduce dependency. Please request a consultation for planning the project.

**Temperature**

Majortrio is designed to operate between -15° and +40°C at atmospheric humidity of 50 percent. If the local temperature is different from the above, please consult Sanpark.

**Conformity Test**

All our systems comply with EC machinery directive 2006/42/EC and TS/EN 14010:2009 +A1:2009.

**Building application documents**

All our systems generally require local approval. Please observe local regulations.

**Maintenance**

Regular maintenance by qualified personnel can be provided by an Annual Service Contract.

**Care and Corrosion Protection**

Due to the corrosion danger, apart from regular maintenance, all our galvanized equipment and platforms must be regularly cleaned up salt water, dirt, leak, any chemical substance, and sand. The garage and pits must be always ventilated well.

**Railings**

If passageways are directly next to the systems, railings have to be provided according to TS EN ISO 13857 by the client according to local requirements, height min. 200 cm.

**Fire Safety**

All fire safety requirement(s) and all possible mandatory item(s) and equipment(s) must comply with local regulations and must be provided by the customer.

**Noise Protection**

In compliance with DIN 4109-1 Noise protection: Maximum sound pressure level in living and sleeping areas 30 dB (A).

User noise like accessing the platform, the slamming of vehicle doors, the vehicle's engine, and brake noise are not subject to the requirements.

In order to provide 30 dB (A) in rooms the following conditions are required;

Additional Sanpark noise protection package according to quote.

Insulation figure of the construction of min R'w= 57 dB (in the customer's responsibility)

Walls that are close to the parking systems must be done as a single wall and deflection resistant with min. m' = 300 kg/m² (in the customer's responsibility)

The solid ceiling above the parking systems with min. m' = 400 kg/m² (in the customer's responsibility)

At differing constructional conditions, additional sound-absorbing methods are in the customer's responsibility.

COMPONENTS**SUBLIFT COMPONENTS**

2 Steel columns with base plates.
 2 Mechanical Locking devices
 2 Platforms
 1 Hydraulic cylinder
 Anchors, screws, connectors, bolts, etc.
 1 Mechanical synchronization system.

Platform Components

Platform profiles
 Side beams
 Adjustable positioning aid
 Platform base sections
 Chamfered ramp
 Screws, nuts, washers, spacers, etc.

Electrical System Components

Emergency stop
 Electrohydraulic lock
 Electro mechanic lock
 Distributor board
 Junction box
 1 Master key for each Sublift

Hydraulic System Components

Hydraulic cylinders
 Solenoid valve
 Safety valve
 Screwed joints
 High-pressure hoses
 Attachments

Hydraulic Unit Component

Hydraulic power unit
 Hydraulic oil reservoir
 Oil filling
 Internal gear Pump
 Pump holder
 Coupling
 3 phase AC motor (2.6 kW, 380 V, 50 Hz)
 Contactor
 Pressure relief valve
 Hydraulic hoses

Sanpark's engineering department is constantly challenging itself to improve its systems. In the event of technological advancement, Sanpark can adopt newer or different technologies, systems, or standards to improve overall quality.

SERVICES TO BE PROVIDED BY THE CUSTOMER**Warning Marking**

According to DIN EN 14010, the floor has to be marked with 10 cm wide yellow-black stripes to indicate the operation area by the purchaser to point out the dangerous area.

**Barriers**

In accordance with DIN EN 13857, barriers may be required in case of passageways in front of, behind, or next to the systems.

**Parking Space Numbering**

Numbering the parking spaces.

**Lighting**

It is in the customer's responsibility to check local regulations regarding the illumination of parking spaces.

**Conduits and Wall Openings**

Any conduit and wall opening work belongs to the customer, yet Sanpark can assist during the planning phase in such cases. Please consult Sanpark if necessary.

**Supply Cable to Master Switch**

The customer must run the supply cable to the master switch during assembly.

**Earth Foundation**

The customer must earth the steel structure with a foundation earth connection and lay equipotential bonding according to local regulations.

**Drainage**

For environmental protection, we advise applying coating the pit floor. Oil and/or fuel separators should be installed in accordance with local regulations. To drain large quantities of water from the yard, the customer must install a water collection channel around the system.

CERTIFICATES

ZERTIFIKAT | CERTIFICATE | CERTIFICAT | CERTIFICADO | CERTIFICAZIONE | 証明書 | 인증서



EG-BAUMUSTERPRÜFBESCHEINIGUNG

TUV AUSTRIA TÜRK ist benannte Stelle
nach der Maschinenrichtlinie 2006/42/EG unter der Nummer 2737

Bescheinigung Nr.: 21-MD-TEC-063-TAT-2021-033

Antragsteller : SANMAK MAKİNE SANAYİ VE TİC. A.Ş.
Çalı Sanayi Bölgesi Çalı Mah. 6. Sk. N:8 Nilüfer / Bursa

Hersteller : SANMAK MAKİNE SANAYİ VE TİC. A.Ş.
Çalı Sanayi Bölgesi Çalı Mah. 6. Sk. N:8 Nilüfer / Bursa

Design des Produkts : Mehrschichtiger, elektrohydraulischer mechanischer Parklift

Typ/Modell : # IDEALIFT H2W1, IDEALIFT H2W2, IDEALIFT H3W1, IDEALIFT H3W2 #
IDEALOW H2W1, IDEALOW H2W2, IDEALOW H3W1, IDEALOW H3W2 #
MAJORLIFT, MAJORTRIO, OPTILIFT, ROBUST-SLIMO #
SUBLIFT H1W1, SUBLIFT H1W1, SUBLIFT H1W2, SUBLIFT H2W1,
SUBLIFT H2W2, SUBLIFT H3W1, SUBLIFT H3W2

Warenzeichen / Marke : SANPARK

**Norm(en)/
Angewandte Regelwerke:** : 2006/42/EG Maschinenrichtlinie
EN ISO 12100:2010
EN 14010:2003+A1:2009

Diese Konformitätsbewertung wird auf Kundenwunsch gemäß Maschinenrichtlinie 2006/42/EG Artikel 12.3.b ausgestellt. Die in Anhang IV aufgeführten Geräte entsprechen der harmonisierten Norm und Anhang I den grundlegenden Gesundheits- und Sicherheitsanforderungen der Richtlinie. Sie bezieht sich nur auf das jeweilige Muster und dessen technische Unterlagen, die zur Einschichtnahme vorgelegt werden.

Technische Datei Nr : 21-MD-TEC-063/TF-01
MIT* Dokument Nr : MD-2737-2100004
Assessor-ID-Nr. : TU-MD-001
Datum/Ort der Begutachtung : 01.10.2021
Ausstellungsdatum : 09.11.2021
Ablaufdatum : 08.11.2026

CE Nach Erstellung der notwendigen technischen Dokumentation sowie der Konformitätserklärung kann die erforderliche CE-Kennzeichnung auf dem Produkt angebracht werden. Weitere relevante Richtlinien sind zu berücksichtigen.

Diese Konformitätserklärung wurde dem Antragsteller auf Grundlage der Ergebnisse der Prüfungen durch den Antragsteller / Hersteller oder einem anerkannten Labor und der im Prüfbericht angeführten Konformitätsbewertung des TÜV AUSTRIA TÜRK ausgestellt. Änderungen der angewandten Regelwerke/Normen sowie der Materialien, der Komponenten, der Fertigung oder der Gestaltung können eine teilweise oder gänzliche Wiederholung der Prüfungen erforderlich machen, um die Gültigkeit der Bescheinigung aufrecht zu erhalten. report and therefore this associated certificate to remain valid.

1 Ministerium für Industrie und Technologie

CERT-MAD-001 EG-BAUMUSTERPRÜFBESCH. EN:2006/42/EG
Revison: 02 Datum: 09.03.2020
Form: 1/1

TÜV AUSTRIA TÜRK
Ausgewiesene Vervielfältigung nur mit Genehmigung des TÜV AUSTRIA TÜRK.
Alle Prüf- und Überwachungsleistungen wurden nach dem QM-System des TÜV AUSTRIA TÜRK durchgeführt.

Cemra Mah. İstifal Cad. Dış. Sk. No:28 PK:34774 Ümraniye / İSTANBUL E-Mail: info@tuvtrk.com.tr

VERIFIED BY: TÜV AUSTRIA TÜRK. This document is a copy of the original document. It is subject to the approval of TÜV AUSTRIA TÜRK.



CERTIFICATE

Sanmak
Makine Sanayi ve Ticaret A.Ş.

ŞANMAK MAKİNA SAN. VE TİC. A.Ş.

ÇALI SANAYİ BÖLGESİ 6. SOK. NO:8
NİLÜFER / BURSA / TÜRKİYE

*Has been assessed and found to Comply with the Requirements of:
Denetlenmiş ve aşağıdaki standardın gerekliliklerine uygunluğu görülmüştür:*

ISO 9001:2015

*The Quality Management System is applicable to:
Kalite Yönetim Sistemi:*

**DESIGN, PRODUCTION AND SERVICE SERVICES OF MACHINES
FOR VEHICLE, LOAD LIFTING AND TRANSPORT**

**TAŞIT, YÜK KALDIRMA VE TAŞIMA AMAÇLI MAKİNALARIN
TASARIMI, ÜRETİMİ VE SERVİS HİZMETLERİ**

Certificate Number: QMS-05807
Belge Numarası: QMS-05807

Certificate Validity Date: 15.12.2021
İlk Belgeleme Tarihi: 15.12.2021

Certificate Period: 3 Years
Belgeleme Periyodu: 3 Yıl

Certificate Validity Date: 14.12.2022
Belge Geçerlilik Tarihi: 14.12.2022

**INTERNATIONAL
ACCREDITED
MANAGEMENT SYSTEMS
CERTIFICATION BODY
MSCB-135**

IQR
IQR Sertifikasyon Onayı

IQR ULUSLARARASI BELGELENDİRME HİZMETLERİ LTD.ŞTİ.
Beşevler Mah. Kocayunus Sk. No:3 Anadolı Han Plaza K:2 Nilüfer / BURSA
Tel: +90 224 226 00 16 Faks: +90 224 249 41 13 www.iqrcert.com e-posta: info@iqrcert.com